

## **3.5/3.9 & 4.2 litre V8 ENGINE**



### **Overhaul Manual**

---

**3.5/3.9 & 4.2 Liter V8 motor  
revisiehandboek**

**Moteur de 3.5/3.9 & 4.2L V8  
Manuel de révision**

**3.5/3.9 & 4.2L V8 motor  
Überholungsanleitung**

**Motore 3.5/3.9 & 4.2 Litri V8  
Manuale di revisione**

**Motor 3.5/3.9 & 4.2 Litro V8  
Manual de revisión**

**Motor da 3.5/3.9 & 4.2L V8  
Manual de revisão**



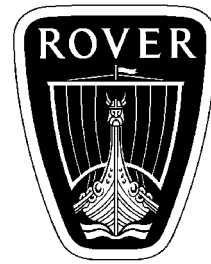

---

---

# V8 ENGINE

---

---

---

---

# OVERHAUL MANUAL

---

---

This overhaul manual is applicable to 3.5, 3.9 and 4.2 Litre V8 engines with or without suffix B added to the engine serial number.

Publication Part No. RCL  
Published by Rover Technical Communication  
© 1996 Rover Group Limited



---

## INTRODUCTION

---

### How to use this Manual

To assist in the use of this Manual the section title is given at the top and the relevant sub-section is given at the bottom of each page.

This manual contains procedures for overhaul of the V8 engine on the bench with the gearbox, clutch, inlet manifold, exhaust manifolds, coolant pump, starter motor, alternator, and all other ancillary equipment removed. For information regarding General Information, Adjustments, removal of oil seals, engine units and ancillary equipment, consult the Repair Manual.

Each major section starts with a contents page, listing the information contained in the relevant sub-sections. To assist filing of revised information each sub-section is numbered from page 1.

The individual overhaul items are to be followed in the sequence in which they appear. Items numbers in the illustrations are referred to in the text.

Overhaul operations include reference to Service tool numbers and the associated illustration depicts the tool. Where usage is not obvious the tool is shown in use. Land Rover tool numbers are quoted, for the equivalent Rover Cars tool number refer to the Service Tool section. Operations also include reference to wear limits, relevant data, and specialist information and useful assembly details.

**WARNINGS, CAUTIONS** and **NOTES** have the following meanings:



**WARNING: Procedures which must be followed precisely to avoid the possibility of injury.**



**CAUTION: Calls attention to procedures which must be followed to avoid damage to components.**



**NOTE: Gives helpful information.**

### References

With the engine and gearbox assembly removed, the crankshaft pulley end of the engine is referred to as the front. References to RH and LH banks of cylinders is taken viewing from the flywheel end of the engine.

Operations covered in this Manual do not include reference to testing the vehicle after repair. It is essential that work is inspected and tested after completion and if necessary a road test of the vehicle is carried out particularly where safety related items are concerned.

### Dimensions

The dimensions quoted are to design engineering specification with Service limits where applicable.

# INTRODUCTION

---

---

## REPAIRS AND REPLACEMENTS

---

When replacement parts are required it is essential that only Rover recommended parts are used.

Attention is particularly drawn to the following points concerning repairs and the fitting of replacement parts and accessories.

Torque wrench setting figures given in this Manual must be used. Locking devices, where specified, must be fitted. If the efficiency of a locking device is impaired during removal it must be renewed.

The terms of the vehicle warranty may be invalidated by the fitting of parts other than Rover Group recommended parts. All Rover Group recommended parts have the full backing of the vehicle warranty.

Rover Group dealers are obliged to supply only Rover Group recommended parts.

---

## SPECIFICATION

---

Rover Group are constantly seeking to improve the specification, design and production of their vehicles and alterations take place accordingly. While every effort has been made to ensure the accuracy of this Manual, it should not be regarded as an infallible guide to current specifications of any particular vehicle.

This Manual does not constitute an offer for sale of any particular component or vehicle. Rover Group dealers are not agents of Rover Group and have no authority to bind the manufacturer by any expressed or implied undertaking or representation.



**DATA**

**Firing order** ..... 1, 8, 4, 3, 6, 5, 7, 2  
 Cylinders 1, 3, 5, 7 - LH side of engine  
 Cylinders 2, 4, 6, 8 - RH side of engine

**Valve springs**

Free length ..... 48.30 mm  
 Fitted length ..... 40.40 mm  
 Load at fitted length .....  $339 \pm 10$  N

**Valves**

Valve stem diameter:  
 Inlet ..... 8.664 to 8.679 mm  
 Exhaust ..... 8.651 to 8.666 mm  
 Valve head diameter:  
 Inlet ..... 39.75 to 40.00 mm  
 Exhaust ..... 34.226 to 34.480 mm  
 Valve installed height - maximum ..... 47.63 mm  
 Valve stem to guide clearance:  
 Inlet ..... 0.025 to 0.066 mm  
 Exhaust ..... 0.038 to 0.078 mm

**Valve guides**

Valve guide installed height ..... 24.13 mm

**Valve seats**

Valve seat angle .....  $460^{\circ} 15'$   
 Valve seat width ..... 1.5 to 2.0 mm  
 Valve face angle .....  $45^{\circ}$

**Oil pump**

Gear to body minimum clearance ..... 0.05 mm

**Oil pressure relief valve**

Spring free length ..... 81.28 mm

**Oil pump - Engine No's with suffix B**

Inner to outer rotor clearance - maximum ..... 0.25 mm  
 Rotors to cover plate clearance - maximum ..... 0.1 mm  
 Drive gear wear step depth - maximum ..... 0.15 mm

**Oil pressure relief valve - Engine No's with suffix B**

Spring free length ..... 60.0 mm

**Camshaft**

Maximum run-out ..... 0.05 mm

# INFORMATION

---

## Piston rings

Ring to groove clearance:

Top compression .....	0.05 to 0.10 mm
2nd compression .....	0.05 to 0.10 mm

Ring fitted gap:

Top compression .....	0.44 to 0.57 mm
2nd compression .....	0.44 to 0.57 mm
Oil control rails .....	0.38 to 1.40 mm
Oil control ring width .....	3.00 mm, maximum

## Pistons

Clearance in bore, measured at bottom of

skirt at right angles to bore .....	0.018 to 0.033 mm
-------------------------------------	-------------------

## Gudgeon pins

Length .....	72.67 to 72.79 mm
Diameter .....	22.215 to 22.220 mm
Clearance in piston .....	0.002 to 0.007 mm

## Connecting rods

Length between centres .....	143.81 to 143.71 mm
------------------------------	---------------------

## Cylinder bore

Cylinder bore diameter:

3.5 engine .....	88.90 mm
3.9 engine .....	94.00 mm
4.2 engine .....	94.00 mm

## Crankshaft

Main journal diameter .....	58.409 to 54.422 mm
Minimum regrind diameter .....	57.393 to 57.406 mm
Maximum out of round .....	0.040 mm
Big-end journal diameter .....	50.800 to 50.812 mm
Minimum regrind diameter .....	49.784 to 49.797 mm
Maximum out of round .....	0.040 mm
End-float .....	0.10 to 0.20 mm

## Main bearings

Main bearing diametrical clearance .....	0.010 to 0.048 mm
Undersizes .....	0.254 mm, 0.508 mm

## Big-end bearings

Big-end bearing diametrical clearance .....	0.015 to 0.055 mm
Undersizes .....	0.254 mm, 0.508 mm
Endfloat on journal .....	0.15 to 0.36 mm

## Flywheel

Flywheel minimum thickness .....	39.93 mm
----------------------------------	----------

## Drive plate

Drive plate setting height .....	8.08 to 8.20 mm
----------------------------------	-----------------



**ENGINE**

Crankshaft pulley bolt	270 Nm
Timing cover to cylinder block bolts **	22 Nm
Camshaft gear bolt	50 Nm
Rocker cover bolts	8 Nm
Rocker shaft to cylinder head bolts	38 Nm
Cylinder head bolts: *	
Outer row	60 Nm
Centre row	90 Nm
Inner row	90 Nm
Cylinder head bolts - Engine No's with suffix B: *	
Stage 1	20 Nm
Stage 2	Then 90°
Stage 3	Further 90°
Lifting eye to cylinder head bolts	25 Nm
Connecting rod bolts	50 Nm
Main bearing cap bolts ***	70 Nm
Rear main bearing cap bolts ***	90 Nm
Flywheel bolts	80 Nm
Drive plate and ring gear assembly bolts	40 Nm
Drive plate adapter bolts	80 Nm
Oil sump drain plug	40 Nm
Oil sump bolts	23 Nm
Oil pressure relief plug	45 Nm
Oil pump cover to timing cover	12 Nm
Oil pump cover plate screws - Engine No's with suffix B ****	4 Nm
Oil strainer bolts	10 Nm
Distributor clamp bolt	20 Nm
Spark plug	15 Nm
Coolant pump/timing cover to cylinder block	22 Nm

\* Lightly oil threads prior to assembly.

\*\* Coat first three threads with Loctite 242 prior to assembly.

\*\*\* Coat threads with lubricant EXP16A (Marston Lubricants) prior to assembly.

\*\*\*\* Coat threads with Loctite 222 prior to assembly.

# INFORMATION

---

---

## GENERAL

---

For bolts and nuts not otherwise specified:

### METRIC

M5 .....	4 Nm
M6 .....	6 Nm
M8 .....	18 Nm
M10 .....	35 Nm
M12 .....	65 Nm
M14 .....	80 Nm
M16 .....	130 Nm

### UNC / UNF

1/4 .....	8-10 Nm
5/16 .....	25 Nm
3/8 .....	40 Nm
7/16 .....	75 Nm
1/2 .....	90 Nm
5/8 .....	135 Nm





**This page is intentionally left blank**

# ENGINE

---

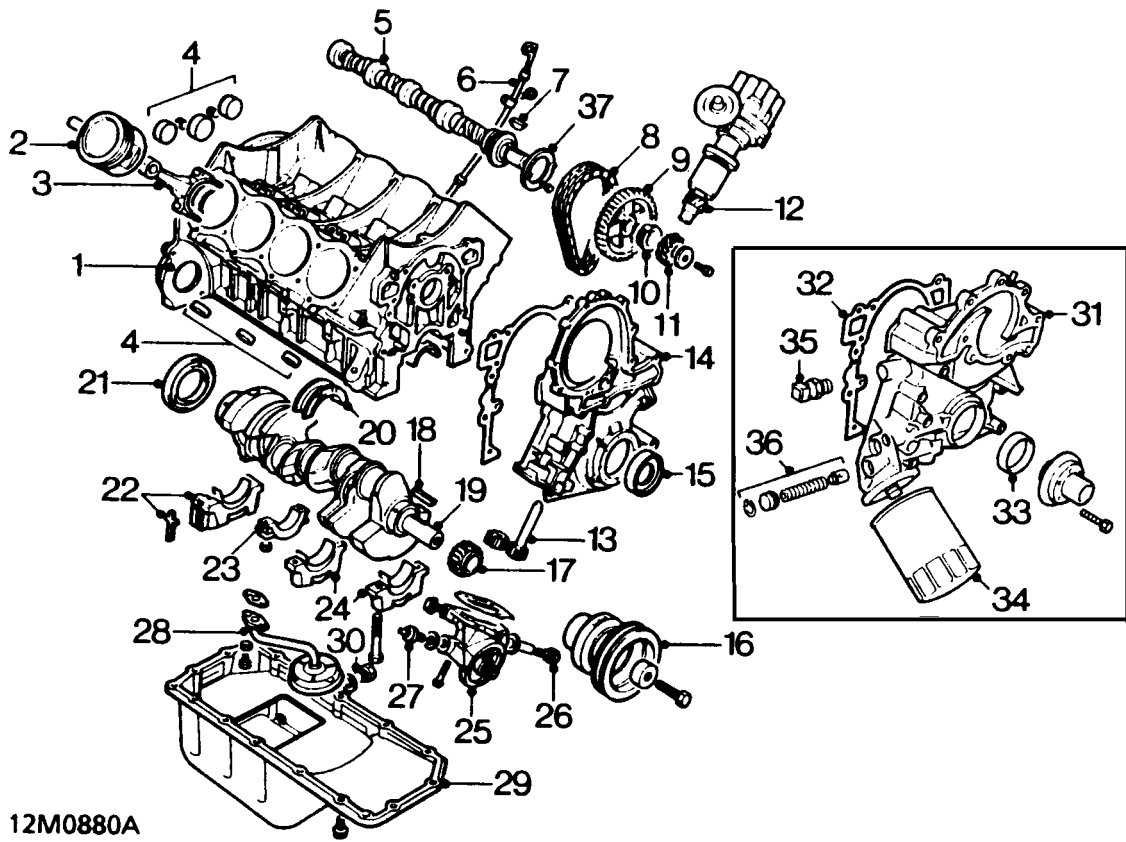



---

**CYLINDER BLOCK COMPONENTS**

---

1. Cylinder block
2. Piston and gudgeon pin
3. Connecting rod
4. Core plugs
5. Camshaft
6. Dipstick
7. Camshaft key
8. Timing chain
9. Camshaft sprocket
10. Spacer
11. Distributor drive gear
12. Distributor
13. Oil pump gears \*
14. Timing cover and gasket \*
15. Timing cover oil seal \*
16. Crankshaft pulley
17. Crankshaft sprocket
18. Woodruff key
19. Crankshaft
20. Centre main bearing shell - upper
21. Crankshaft rear oil seal
22. Rear main bearing cap and side seals
23. Connecting rod cap
24. Main bearing caps
25. Oil pump cover \*
26. Oil pressure relief valve assembly \*
27. Oil pressure switch \*
28. Oil pump suction pipe and strainer
29. Sump
30. Drain plug
31. Timing cover \*\*
32. Timing cover gasket \*\*
33. Timing cover oil seal \*\*
34. Oil filter \*\*
35. Oil pressure switch \*\*
36. Oil pressure relief valve assembly \*\*
37. Camshaft thrust plate - if fitted

\* Engine numbers without suffix B

\*\* Engine numbers with suffix B

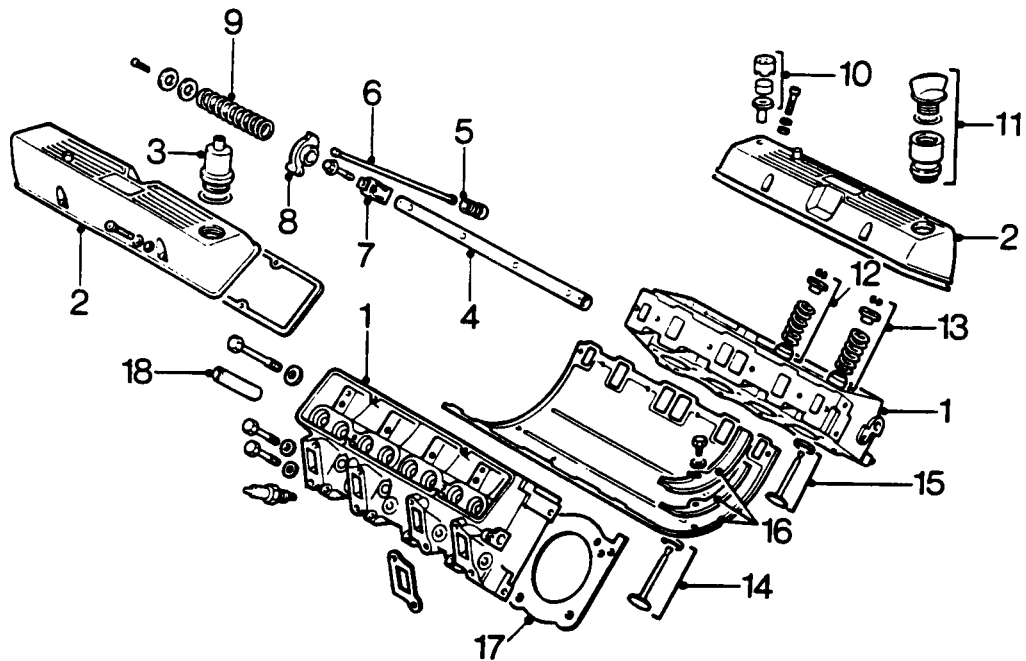

12M0881

---

## CYLINDER HEAD COMPONENTS

---

- |                           |   |
|---------------------------|---|
| 1. Cylinder head          | 11. Engine oil filler cap                       |
| 2. Rocker cover           | 12. Inlet valve seal, spring, cap, and collets  |
| 3. PCV filter             | 13. Exhaust valve seal, spring, cap and collets |
| 4. Rocker shaft           | 14. Inlet valve and seat                        |
| 5. Tappet                 | 15. Exhaust valve and seat                      |
| 6. Pushrod                | 16. Inlet manifold gasket and seals             |
| 7. Rocker shaft bracket   | 17. Cylinder head gasket                        |
| 8. Rocker arm             | 18. Valve guide                                 |
| 9. Rocker shaft spring    |   |
| 10. PCV air intake filter |   |

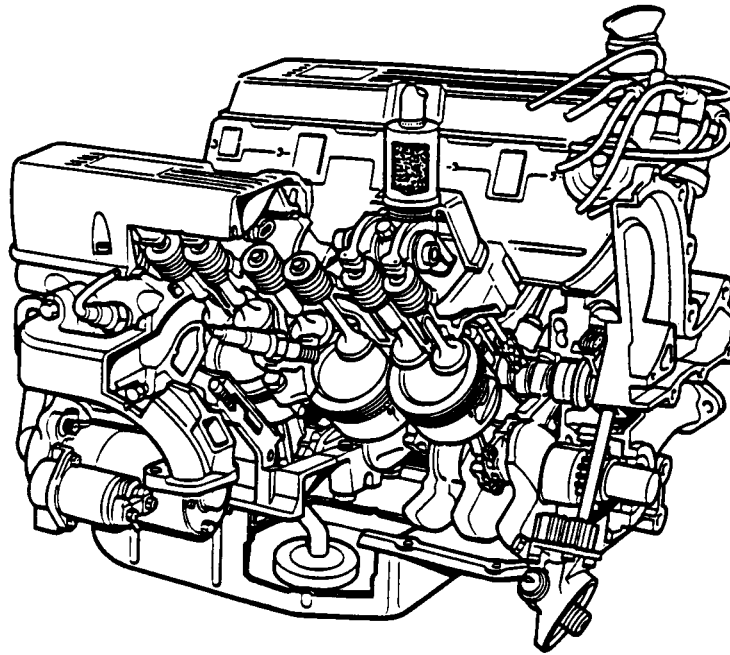

12M1087

---

### Operation

---

The V8 engine is an eight cylinder, water cooled unit comprising of cast aluminium cylinder block and cylinder heads.

The two banks of steel cylinder liners which are pressed down to stops in the cylinder block, are set at 90° to each other. The crankshaft is carried in five main bearings, end-float being controlled by the thrust faces of the upper centre main bearing shell.

The centrally located camshaft is driven by the crankshaft via an inverted tooth chain. The valves are operated by rockers, pushrods and hydraulic tappets. Distributor drive is by skew gear from the front of the camshaft.

The aluminium alloy, pistons have two compression rings and an oil control ring and are secured to the connecting rods by semi-floating gudgeon pins. On later 4.2L engines the gudgeon pin is offset 0.5mm, identified by an arrow mark on the piston crown, which must always point to the front of the engine. Plain, big-end bearing shells are fitted to each connecting rod.

# ENGINE

---

## Lubrication - Engine numbers without suffix B

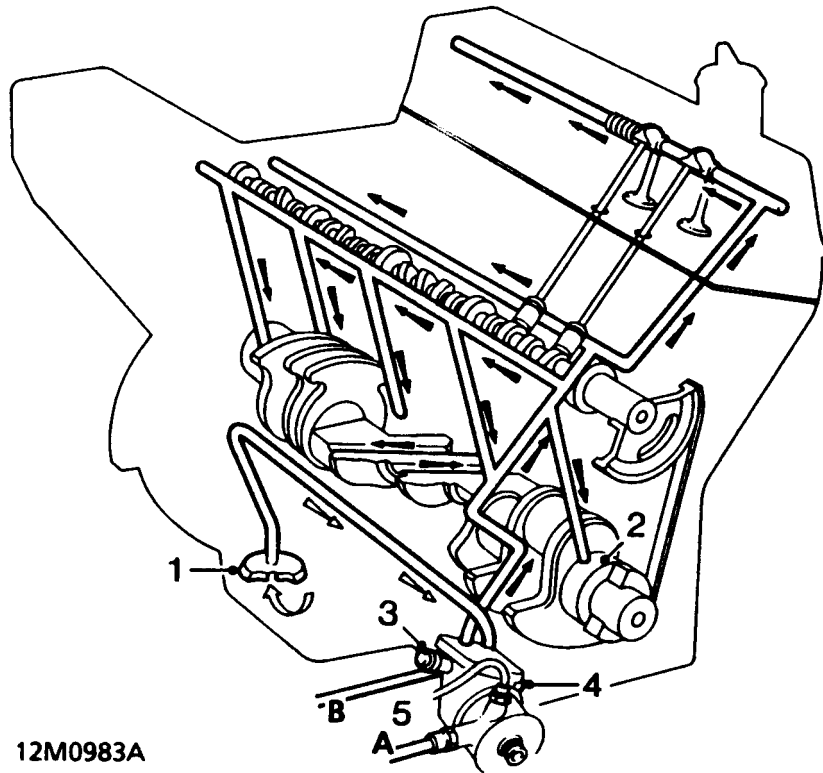

1. Oil strainer
2. Crankshaft main bearing oil feed
3. Oil pressure relief valve
4. Oil pump

5. Main gallery
  - A Oil to cooler
  - B Oil from cooler



## Lubrication - Engine numbers with suffix B

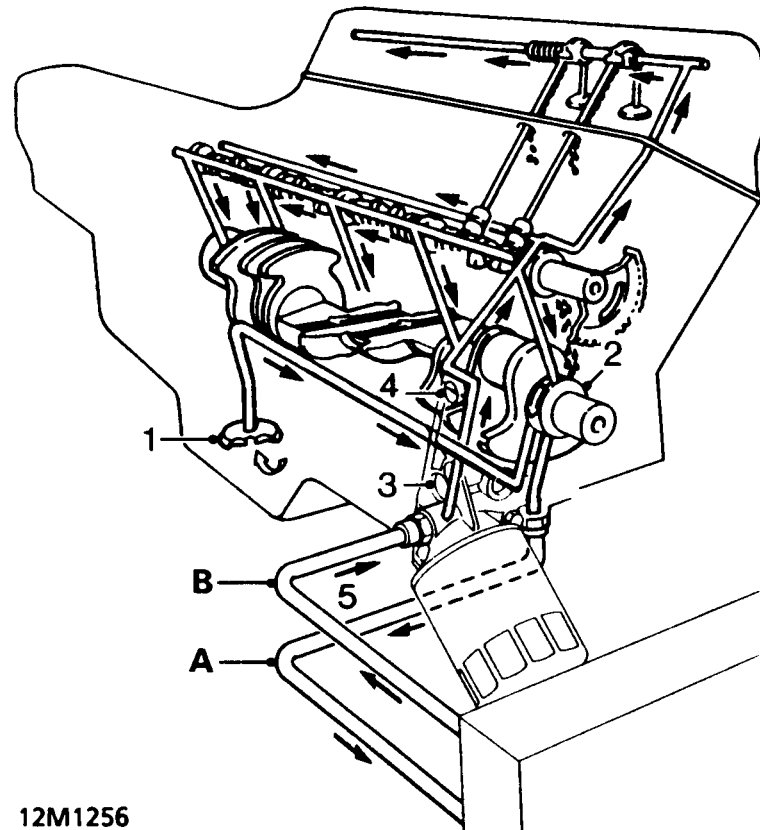

12M1256

- |  |   |
|--|---|
| <ul style="list-style-type: none"> <li>1. Oil strainer</li> <li>2. Oil pump</li> <li>3. Pressure relief valve</li> <li>4. Oil pressure switch</li> </ul> | <ul style="list-style-type: none"> <li>5. Main gallery               <ul style="list-style-type: none"> <li>A Oil to cooler</li> <li>B Oil from cooler</li> </ul> </li> </ul> |
|--|---|

## Engine numbers without suffix B

The full flow lubrication system uses an external gear pump which is driven by the distributor drive shaft. The oil pump gears are housed in the timing cover and the oil pressure relief valve and warning light switch are fitted to the oil pump cover.

## Engine numbers with suffix B

The full flow lubrication system uses a gear type oil pump driven from the crankshaft. The assembly is integral with the timing cover which also carries the full flow oil filter, oil pressure switch and pressure relief valve.

## All engines

Oil is drawn from the pressed steel sump through a strainer and into the oil pump, excess pressure being relieved by the pressure relief valve. The oil pressure warning light switch is screwed into the oil pump cover and registers the oil pressure in the main oil gallery on the outflow side of the filter. Pressurised oil passes through an oil cooler - if fitted to the full flow oil filter and to internal drillings in the crankshaft where it is directed to each main bearing and to the big end bearings via Nos. 1, 3 and 5 main bearings. An internal drilling in the cylinder block directs oil to the camshaft where it passes through further internal drillings to the hydraulic tappets, camshaft journals and rocker shaft. Lubrication to the thrust side of the cylinders is by oil grooves machined in each connecting rod big end joint face, which are timed to align with holes in the big end journals on the power and exhaust strokes.

# ENGINE

## Distributor drive and timing chain lubrication

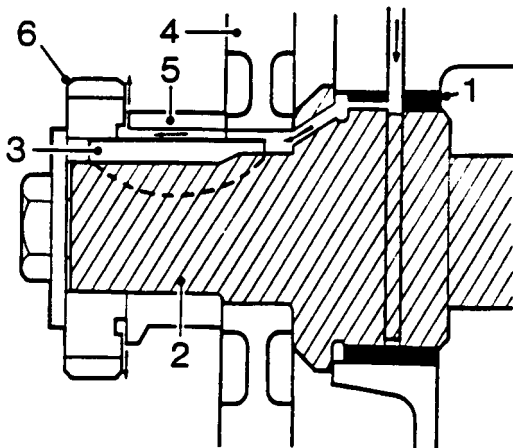

12M1086

1. Bearing
2. Camshaft
3. Key
4. Camshaft timing chain sprocket
5. Spacer
6. Distributor drive gear

The distributor drive and timing chain are lubricated from the camshaft front bearing. The feed to the timing chain is channelled along the camshaft sprocket, key and spacer.

## Hydraulic tappets

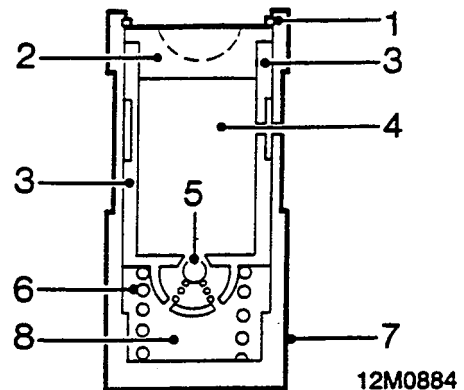

12M0884

1. Clip
2. Pushrod seat
3. Inner sleeve
4. Upper chamber
5. Non-return ball valve
6. Spring
7. Outer sleeve
8. Lower chamber - high pressure

The purpose of the hydraulic tappet is to provide maintenance free and quiet operation of the inlet and exhaust valves. It achieves this by utilising engine oil pressure to eliminate the mechanical clearance between the rockers and the valve stems.

During normal operation, engine oil pressure present in the upper chamber passes through the non-return ball valve and into the lower, high pressure, chamber.

When the cam begins to lift the outer sleeve, the resistance of the valve spring felt through the push rod and seat causes the tappet inner sleeve to move downwards inside the outer sleeve. This downward movement of the inner sleeve closes the ball valve and increases the pressure in the lower, high pressure chamber, sufficiently to ensure that the push rod opens the valve fully.

As the tappet moves off the peak of the cam the ball valve opens to equalise the pressure in both chambers which ensures the valve closes when the tappet is on the back of the cam.







---

**ROCKER SHAFTS**

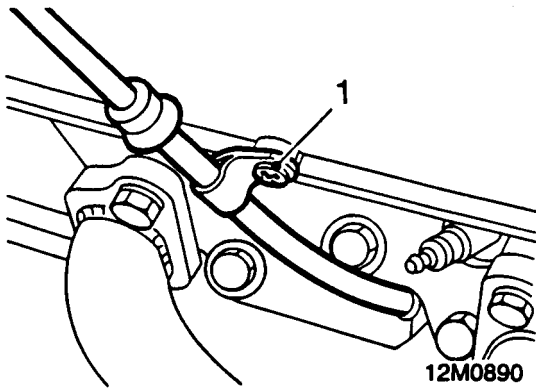

---

**Rocker shaft - remove**

---

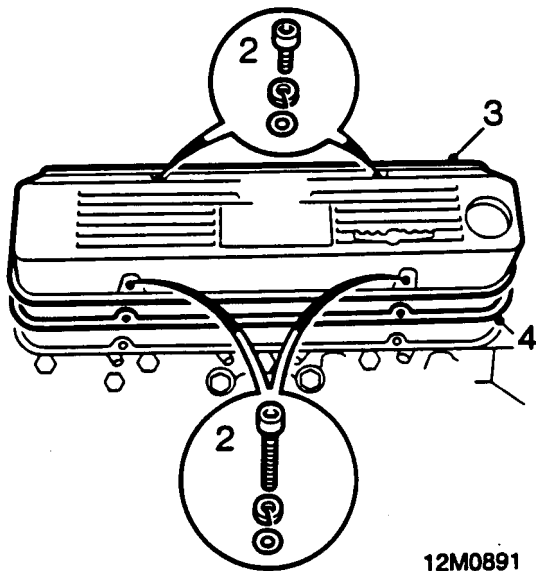

1. LH rocker shaft only: Remove screw securing dipstick tube to rocker cover.



2. Remove 4 screws securing rocker cover to cylinder head.

**NOTE:** Mark position of 2 longer screws.



3. Remove rocker cover.
4. Remove and discard gasket from rocker cover.
5. Mark each rocker shaft in relation to original cylinder head.



**CAUTION:** Incorrect fitment of rocker shafts will lead to an oil feed restriction.

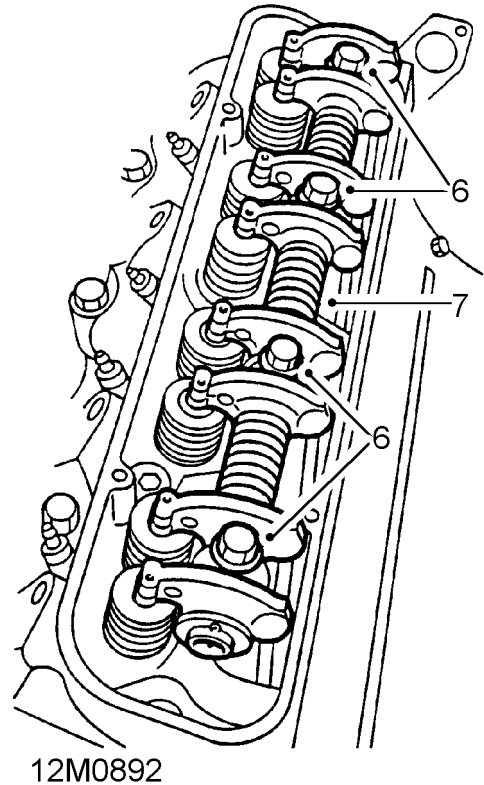

6. Progressively slacken and remove 4 bolts securing rocker shaft assembly to cylinder head.
7. Remove rocker shaft assembly.
8. Remove pushrods and store in fitted order.

# ENGINE

## Dismantle

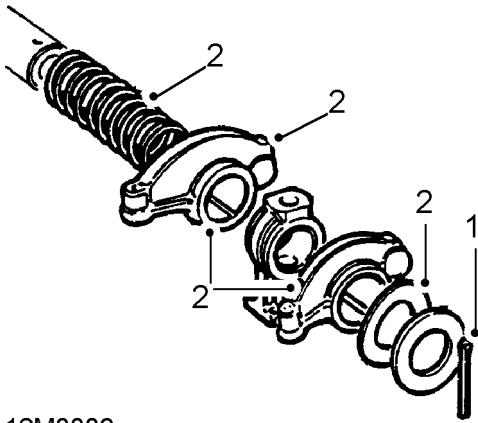

12M0886

1. Remove split pin from one end of rocker shaft.
2. Remove plain washer, wave washer, rocker arms, brackets and springs.

## Inspect

1. Thoroughly clean components.
2. Inspect each component for wear, in particular rocker arms and shafts. Discard weak or broken springs.
3. Inspect pushrod seats in rocker arms.
4. Check pushrods for straightness and inspect ball ends for damage, replace as necessary.

## Assembly

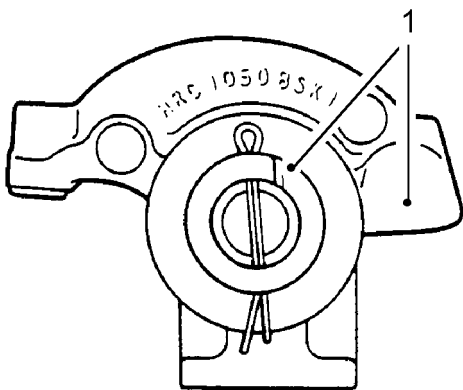

12M0887

1. Assemble rocker shafts with identification groove at one o'clock position with push rod end of rocker arm to the right.



**CAUTION:** If rocker shafts are incorrectly assembled and fitted to engine, oil supply to rocker arms will be restricted.

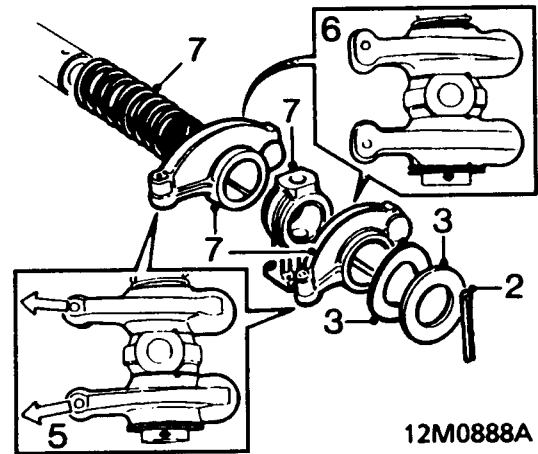

12M0888A

2. Fit new split pin to one end of rocker shaft.
3. Fit plain washer and wave washer.
4. Lubricate rocker arm bushes with clean engine oil.
5. Early type rocker arms are angled, and must be fitted with the valve end of the rocker arms angled away from each other as illustrated.
6. On later type rocker arms the valve end is offset and must be fitted as illustrated.



**NOTE:** Early and late rocker arms are interchangeable provided the complete set is changed.

7. Assemble rocker arms, brackets and springs to rocker shaft.
8. Compress springs, fit wave washer, plain washer and secure with new split pin.



### Rocker shaft - refit

1. Lubricate pushrods with engine oil.
2. Fit pushrods in removed order.

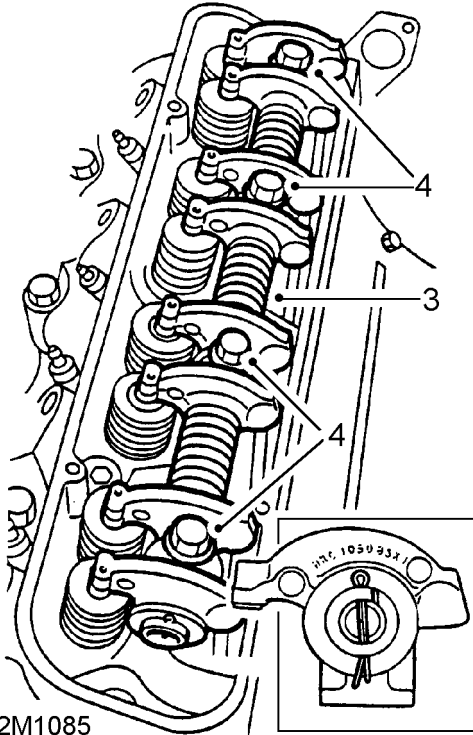

12M1085

3. Fit each rocker shaft assembly, ensuring identification groove is uppermost and towards front of engine on RH side and towards rear of engine on LH side.



**CAUTION: Incorrect fitment will result in an oil feed restriction.**

4. Fit bolts and tighten to correct torque.
5. Clean gasket surface in rocker cover using Bostik cleaner 6001 or equivalent, and allow to dry.

6. Apply a thin coating of Bostik 1775 or equivalent impact adhesive to mating surfaces of rocker cover and gasket.
7. Allow adhesive to cure, then fit gasket to rocker cover.



**CAUTION: Gasket fits one way round only, it must be fitted accurately as subsequent movement will destroy bonding.**

8. Fit rocker cover to cylinder head, fit screws and tighten to correct torque.



**CAUTION: The 2 short screws must be fitted on side of cover nearest centre of engine.**

9. **LH rocker shaft only:** Align dipstick tube to rocker cover, fit and tighten screw.

# ENGINE

## CYLINDER HEAD

### Cylinder head - remove

1. Remove rocker shaft assembly.
2. Mark heads LH and RH for reassembly.

#### Engine numbers without suffix B

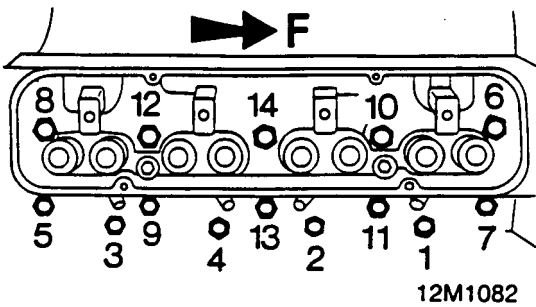

**NOTE:** RH cylinder head illustrated

3. Using sequence shown, remove 14 bolts securing cylinder head to cylinder block.

#### Engine numbers with suffix B

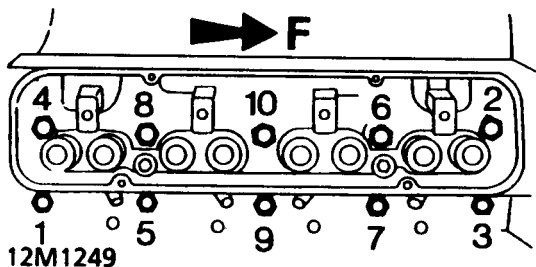

**NOTE:** RH cylinder head illustrated

4. Using sequence shown, remove and discard 10 bolts securing cylinder head to cylinder block.

**NOTE:** No bolts are fitted in the four lower holes in each cylinder head.

### All engines

5. Release cylinder head from 2 dowels and remove cylinder head.
6. Remove and discard cylinder head gasket.

### Valves and springs - remove

1. Remove spark plugs.

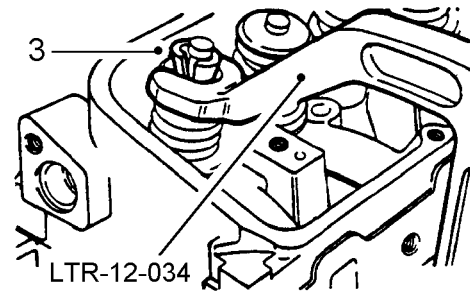

12M0895

G2

2. Using valve spring compressor **LRT-12-034** or a suitable alternative, compress valve spring.
3. Remove 2 collets.

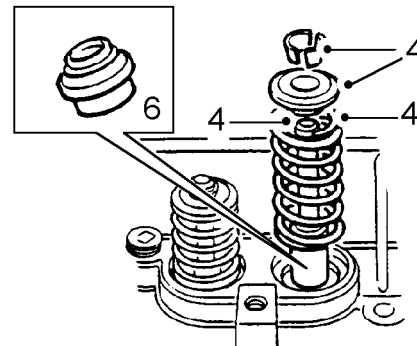

12M0896

4. Release spring compressor and remove valve, valve spring cap and valve spring.
5. Repeat above operations for remaining valves.

**CAUTION:** Keep valves, springs, caps and collets in fitted order.

6. Remove and discard valve stem oil seals.



### Valves, valve springs and guides - inspection

1. Clean cylinder head, valve springs, valves and valve guide bores.
2. Check existing valve stem and head diameters.
3. Check valve stem to guide clearance using new valves.

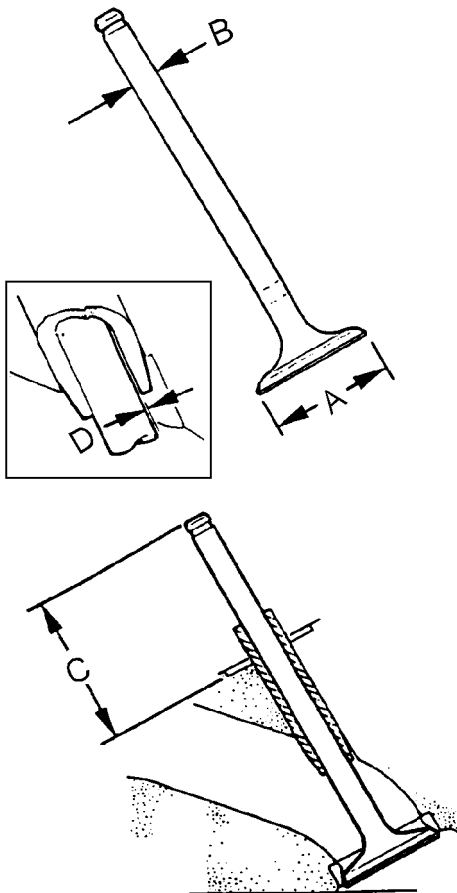

12M0897

4. Renew valves and guides as necessary.  
Valve head diameter **A**:  
Inlet = 39.75 to 40.00 mm  
Exhaust = 34.226 to 34.48 mm  
Valve stem diameter **B**:  
Inlet = 8.664 to 8.679 mm  
Exhaust = 8.651 to 8.666 mm
5. Check installed height of each valve.  
Valve installed height **C** = 47.63 mm
6. Renew valve/valve seat insert as necessary.

7. Check valve stem to guide clearance.  
Valve stem to guide clearance **D**:  
Inlet = 0.25 to 0.66 mm  
Exhaust = 0.38 to 0.78 mm
8. Check condition of valve springs:  
Free length = 48.30 mm  
Fitted length = 40.40 mm  
Load at fitted length =  $339 \pm 10\text{N}$   
Load at valve open length =  $736 \pm 22\text{N}$



**CAUTION: Valve springs must be replaced as a complete set.**

### Valve guide - renew

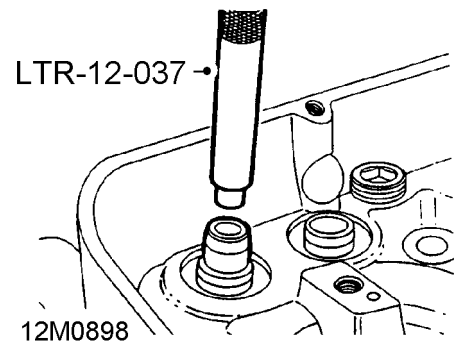

1. Using valve guide remover, **LRT-12-037** press valve guide out from combustion chamber side of cylinder head.



**NOTE: Service valve guides are 0.025mm oversize on outside diameter to ensure interference fit.**

2. Lubricate new valve guide with engine oil and place in position.

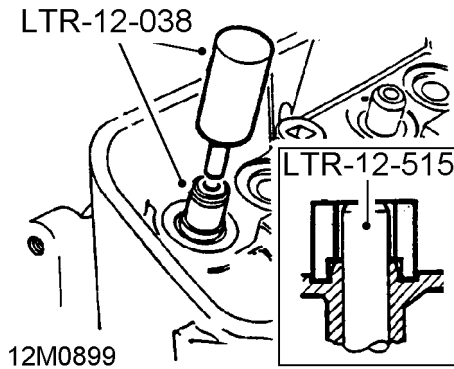

3. Using **LRT-12-038** partially press guide into cylinder head, remove tool.
4. Fit **LRT-12-515** over valve guide and continue to press guide into cylinder head until tool contacts spring seat. Remove tool.  
Valve guide installed height **A** = 24.13 mm

## Valve seat insert - inspection

1. Check valve seat inserts for pitting, burning and wear. Replace inserts as necessary.

## Valve seat insert - renew



**NOTE:** Service valve seat inserts are available 0.25 mm oversize on outside diameter to ensure interference fit.

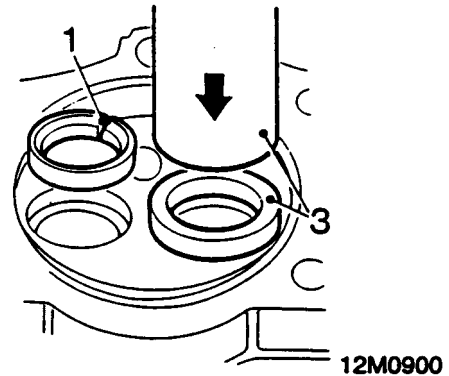

1. Grind a crescent in seat insert, until thin enough to break using a cold chisel.



**CAUTION:** Do not damage counterbore.

2. Heat cylinder head evenly to approximately 65°C.
3. Using a suitable mandrel, press new insert fully into counterbore.
4. Allow cylinder head to air cool.



### Valve seats - renew

1. Check condition of valve seats and valves that are to be reused.
2. Remove carbon from valves and valve seats.

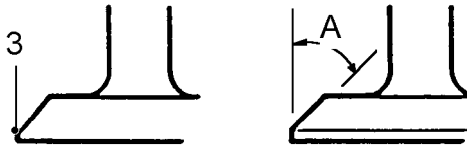

12M0901

3. Reface valves as necessary. If a valve has to be ground to a knife-edge to obtain a true seat, fit a new valve.

Valve seating face angle  $A = 45^\circ$

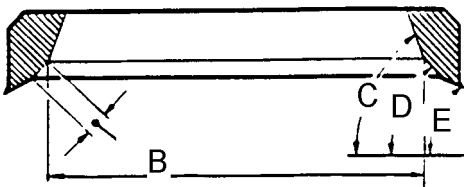
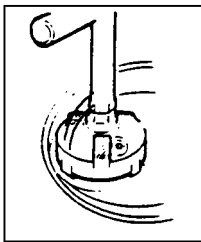

12M0918

4. Cut valve seats using **LRT-12-501** with **LRT-12-503** and **LRT-12-504**.

Valve seat:

Width **A**: Inlet = 37.03 mm

Exhaust = 31.50 mm

Width **B** = 1.5 - 2.00 mm

Angle **C** =  $70^\circ$

Angle **D** =  $46^\circ \pm 15'$

Angle **E** =  $20^\circ$

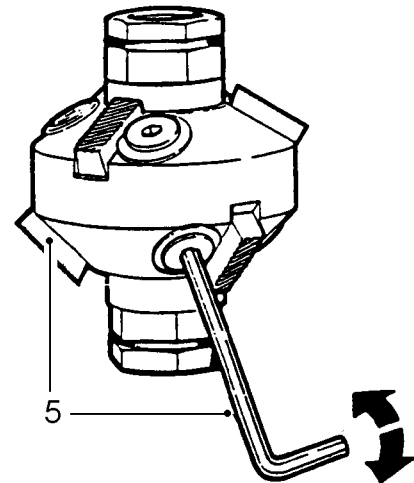

12M0902

5. Ensure cutter blades are correctly fitted to cutter head with angled end of blade downwards, facing work, as illustrated. Check that cutter blades are adjusted so that middle of blade contacts area of material to be cut. Use light pressure and remove only minimum of material necessary.

# ENGINE

## Valves and springs - refit

1. Lap each valve to its seat using fine grinding paste.
2. Clean valve and seat.

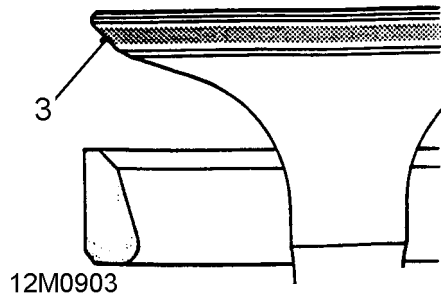

3. Coat valve seat with a small quantity of engineers blue, insert valve and press it into position several times without rotating. Remove valve and check for even and central seating. Seating position shown by engineers blue should be in centre of valve face.

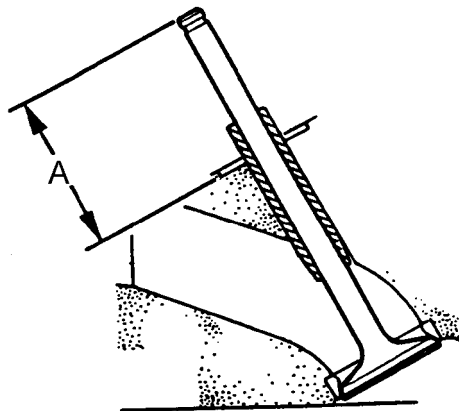

4. Check valve installed height if valve seats have been recut or new valves or valve seat inserts have been fitted.  
Valve installed height  $A = 47.63$  mm
5. Thoroughly clean cylinder head, blow out oilways and coolant passages.
6. Fit new valve stem oil seals, lubricate valve stems, fit valves, valve springs and caps, compress valve springs using **LRT-12-034** and fit collets.
7. Using a wooden dowel and mallet, lightly tap each valve stem two or three times to seat valve cap and collets.

## Cylinder head - refit

1. Clean cylinder block faces using a suitable release agent and plastic scraper; ensure that bolt holes in cylinder block are clean and dry.



**CAUTION: Do not use metal scraper or machined surfaces may be damaged.**

2. *Engine numbers without suffix B:* Thoroughly clean threads of cylinder head bolts.



**CAUTION: Cylinder head bolts - Cylinder head bolts fitted to engines without suffix B added to serial number are not interchangeable with those fitted to engines with suffix B added to serial number.**

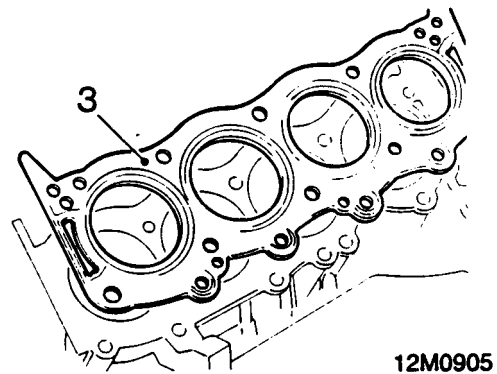

3. Fit cylinder head gasket with the word 'TOP' uppermost.



**NOTE: Gasket must be fitted dry.**



**CAUTION: Engines without suffix B have a steel gasket whilst engines with suffix B have a composite gasket. The two types of gasket are not interchangeable and it is essential to ensure that the correct type of gasket is fitted.**

4. Carefully fit cylinder head and locate on dowels.
5. Lightly oil threads of cylinder head bolts.





**Engine numbers without suffix B**

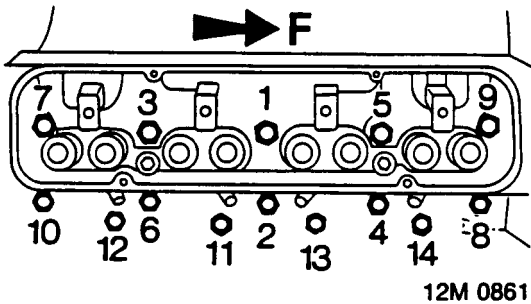

**NOTE:** RH cylinder head illustrated

6. Fit cylinder head bolts:  
Long bolts: 1, 3 and 5.  
Medium bolts: 2, 4, 6, 7, 8, 9, and 10.  
Short bolts: 11, 12, 13 and 14.
7. Using sequence shown, progressively tighten cylinder head bolts to correct torque.

**Engine numbers with suffix B**

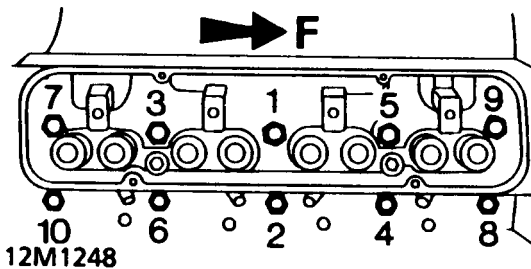

**NOTE:** RH cylinder head illustrated

8. Fit new cylinder head bolts:  
Long bolts: 1, 3 and 5  
Short bolts: 2, 4, 6, 7, 8, 9 and 10



**NOTE:** There are no bolts fitted in the four lower holes in each cylinder head.

9. Using sequence shown, tighten cylinder head bolts to:  
Stage 1 - Correct torque  
Stage 2 - 90°  
Stage 3 - Further 90°

**All engines**

10. Fit rocker shaft assembly.

**TIMING CHAIN AND GEARS**

**Distributor - remove**

1. Remove distributor cap.
2. Rotate crankshaft until centre line of rotor arm is aligned with No. 1 spark plug segment in distributor cap and No. 1 piston is at TDC.

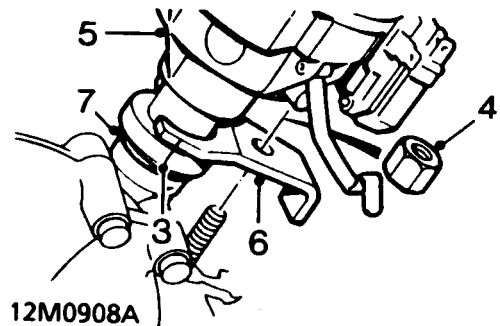

3. Scribe an alignment mark between distributor body and clamp.
4. Remove nut securing distributor clamp.
5. Remove distributor.
6. Remove clamp.
7. Remove and discard 'O' ring from distributor.

# ENGINE

## Sump - remove

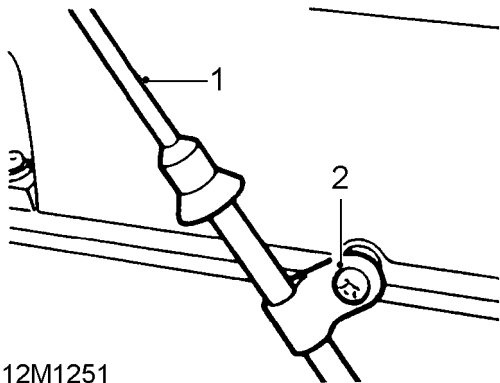

1. Remove dipstick.
2. Remove screw securing dipstick tube to LH rocker cover.

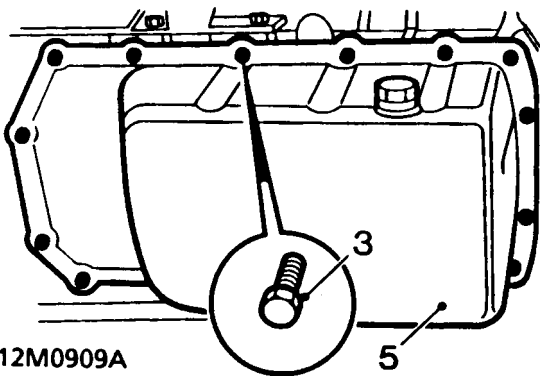

3. Remove 16 bolts securing sump to cylinder block.



**NOTE:** Engine numbers with suffix B, 17 bolts are used to secure sump to cylinder block.

4. Carefully release sump from cylinder block.



**CAUTION:** Take care not to damage sealing faces of cylinder block and sump.

5. Remove sump.

## Timing cover - remove - Engine numbers without suffix B

1. Remove crankshaft pulley bolt and collect spacer washer.
2. Remove crankshaft pulley.

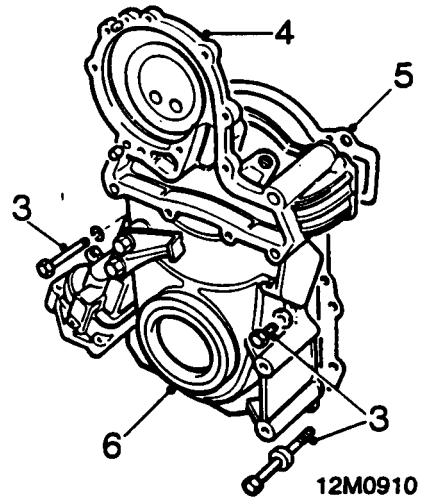

3. Remove bolts and nut securing timing cover to cylinder block.
4. Release and remove timing cover.
5. Remove and discard gasket.
6. Remove and discard oil seal from timing cover.



**Timing cover - remove - Engine numbers with suffix B**



**NOTE:** Timing cover, oil pump and oil pressure relief valve are only supplied as an assembly.

1. Using assistance, restrain flywheel and remove crankshaft pulley bolt; collect spacer washer.
2. Remove crankshaft pulley.

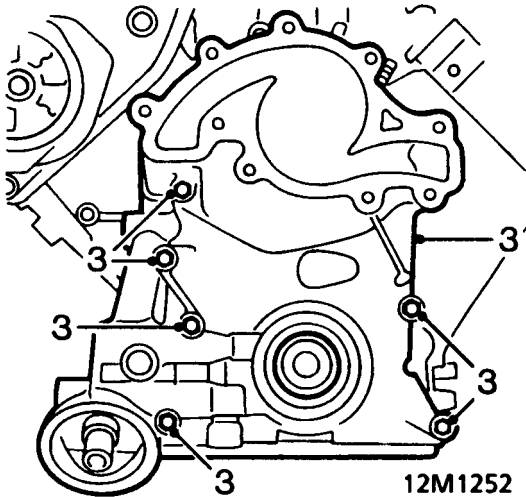

3. Noting their fitted position, remove bolts securing timing cover to cylinder block; remove cover.



**NOTE:** Dowel located.

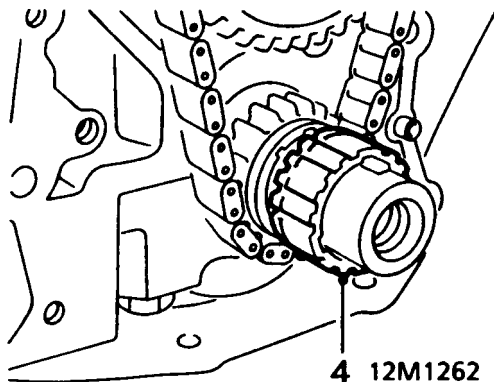

4. Remove oil pump drive gear.
5. Remove and discard gasket.
6. Remove and discard oil seal from timing cover.

**Timing gears - remove**

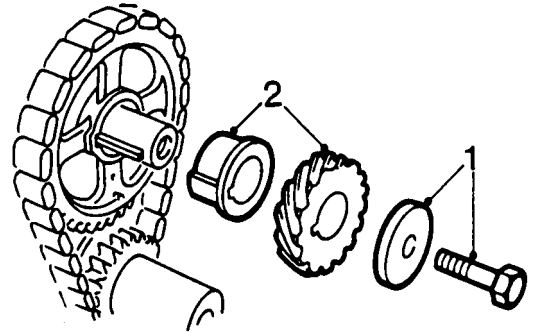

12M0911

1. Restrain camshaft gear and remove bolt securing gear, collect washer.
2. Remove distributor drive gear and spacer.

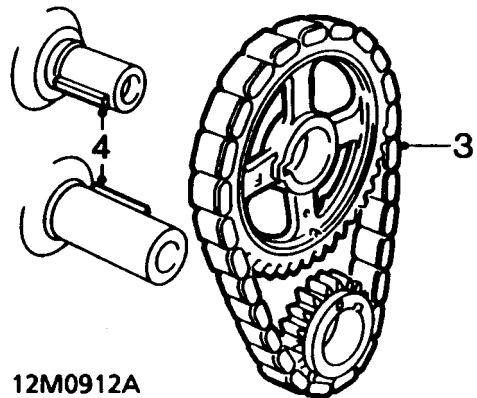

12M0912A

3. Remove timing chain and gears as an assembly.
4. Collect Woodruff keys from camshaft and crankshaft.

**Timing gears - inspection**

1. Thoroughly clean all components.
2. Inspect distributor drive gear for wear.
3. Inspect timing chain links and pins for wear.
4. Inspect timing chain sprockets for wear. Renew parts as necessary.

# ENGINE

## Timing gears - refit

1. Clean gear locations on camshaft and crankshaft, fit Woodruff keys.

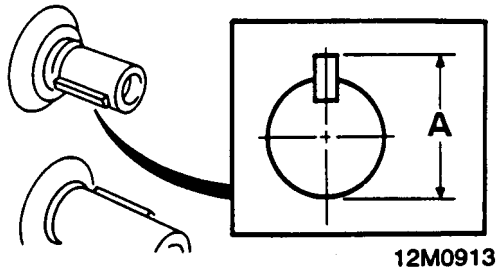

2. Check camshaft Woodruff key is fully engaged in keyway.

**CAUTION:** Space between Woodruff key and keyway acts as an oil feed. It is therefore most important that key is properly seated and parallel to axis of camshaft. Overall dimension 'A' must not exceed 30.15 mm.

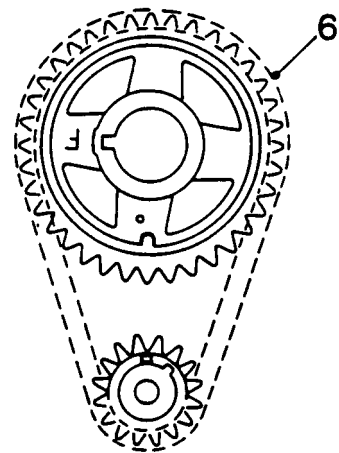

6. Position timing gears on work surface with timing marks upwards and aligned.
7. Fit timing chain around gears, keeping timing marks aligned.
8. Fit gear and chain assembly.

**NOTE:** Timing marks and 'F' mark on camshaft gear must be facing forwards.

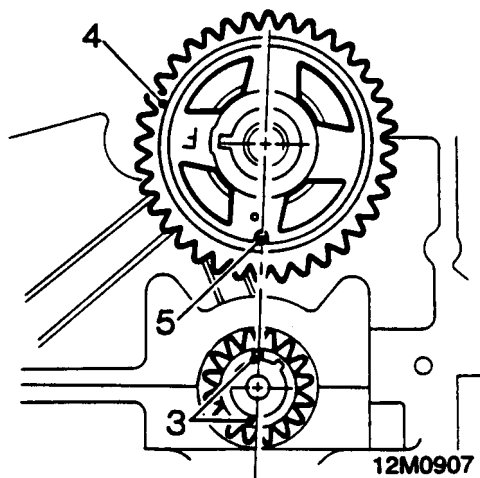

3. Temporarily fit crankshaft gear, and if necessary turn crankshaft to bring timing mark on gear to the twelve o'clock position, remove gear.
4. Temporarily fit camshaft gear with marking 'F' facing forwards.
5. Turn camshaft until mark on camshaft sprocket is at the six o'clock position, remove gear without moving camshaft.

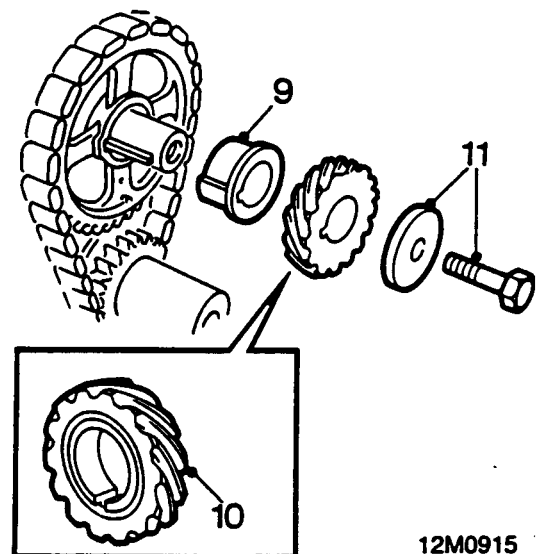

9. Fit spacer to camshaft with flange facing forwards.
10. Fit distributor drive gear to camshaft with grooved face towards camshaft gear.
11. Fit camshaft gear bolt and washer, restrain camshaft gear and tighten bolt to correct torque.



### Timing cover - refit - Engine numbers without suffix B

1. Clean sealant from threads of cover bolts.
2. Clean all traces of old gasket material from timing cover and mating face of cylinder block.



**CAUTION: Use a plastic scraper.**

3. Use a lint free cloth and thoroughly clean oil seal location in timing cover.
4. Lubricate new oil seal sealing surfaces with engine oil.

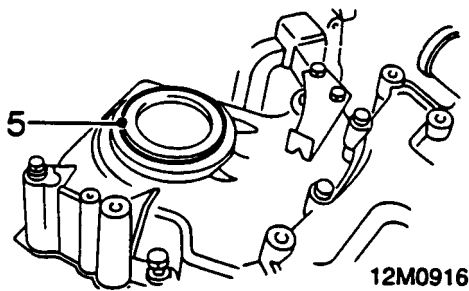

5. Locate seal to timing cover and press seal in squarely until flush with front face of timing cover.
6. Position new gasket to cylinder block.
7. Coat threads of timing cover bolts with Loctite 242 sealant.
8. Fit timing cover, fit bolts and nut and tighten to correct torque.
9. Fit crankshaft pulley.
10. Fit spacer washer to pulley bolt, fit bolt and tighten to correct torque.

### Timing cover - refit - Engine numbers with suffix B



**NOTE: Timing cover, oil pump and oil pressure relief valve are only supplied as an assembly.**

1. Clean sealant from threads of timing cover bolts.
2. Clean all traces of gasket material from mating faces of timing cover and cylinder block.



**CAUTION: Use a plastic scraper.**

3. Clean oil seal location in timing cover.
4. Lubricate oil pump gears and oil seal recesses in timing cover with engine oil.
5. Apply Hylosil jointing compound to new timing cover gasket, position gasket to cylinder block.
6. Position oil pump drive gear in timing cover with groove towards front of timing cover.

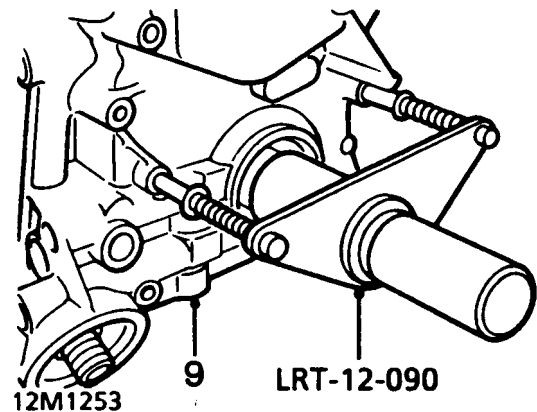

7. Locate tool **LRT-12-090** on timing cover and oil pump drive gear.
8. Position timing cover to cylinder block and at the same time, rotate tool **LRT-12-090** until drive gear keyway is aligned with Woodruff key.
9. Fit timing cover to cylinder block.
10. Smear threads of timing cover bolts with Loctite 242 sealant, fit bolts and tighten progressively to the correct torque.



**NOTE: Do not fit coolant pump bolts at this stage.**

11. Remove tool **LRT-12-090**.

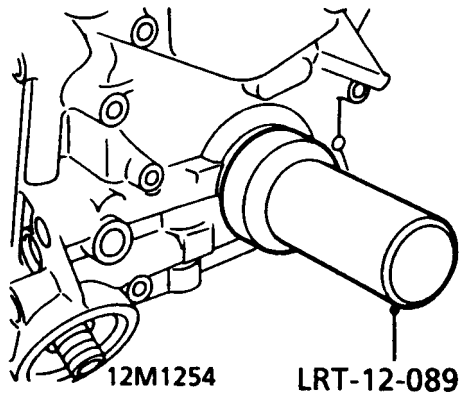

12. Lubricate new timing cover oil seal with engine oil.
13. Fit timing cover oil seal using tool **LRT-12-089**.
14. Fit crankshaft pulley, fit bolt and spacer washer; tighten bolt to correct torque.

## Sump - refit

1. Remove all traces of old sealant from mating faces of cylinder block and sump.

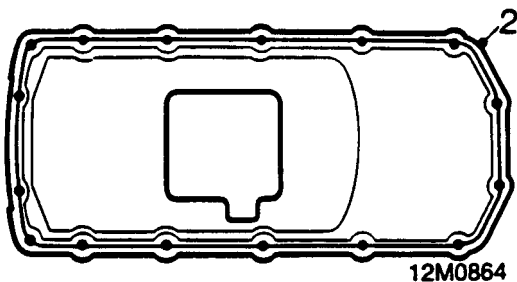

2. Clean mating faces with suitable solvent and apply a 2 mm bead of Hylosil white silicone sealant to sump joint face as shown.
3. Fit sump, taking care not to damage sealant bead.
4. Fit sump bolts and working from the centre outwards, tighten progressively to correct torque.
5. Fit and tighten screw securing dipstick tube to LH rocker cover.
6. Fit dipstick.

## Distributor - refit

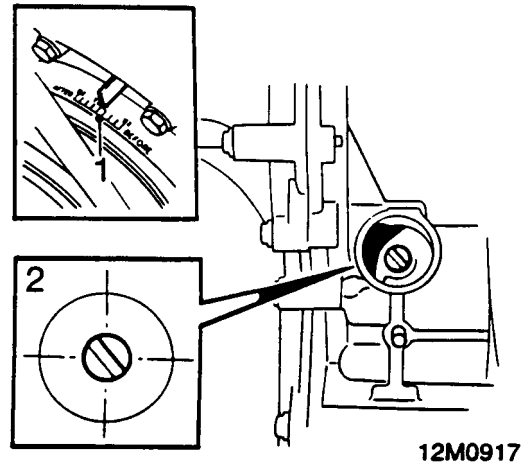

1. Ensure timing pointer is aligned with 30 mark on crankshaft pulley and No.1 piston is on the compression stroke.
2. **Engine numbers without suffix B:** Position oil pump drive shaft tongue at the ten to four position.
3. Lubricate a new 'O' ring with engine oil and fit to distributor.

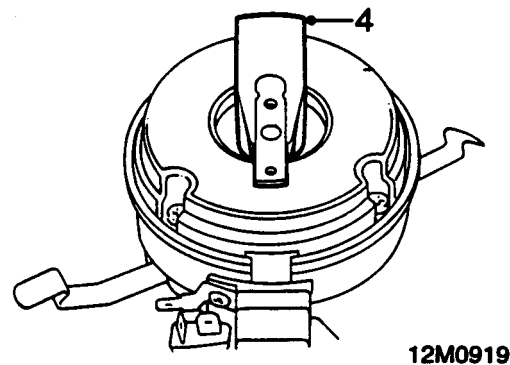

4. Turn distributor drive until rotor arm is approximately 30° anti-clockwise from No.1 spark plug segment in distributor cap.
5. Insert distributor into timing cover, engage drive gear and push distributor down until 'O' ring enters bore; position distributor clamp on stud.



6. *Engine numbers without suffix B*: Locate slotted adaptor to oil pump drive shaft tongue.
7. Check that centre line of rotor arm is aligned with No.1 spark plug segment in distributor cap and reference marks on distributor body and clamp are aligned; reposition distributor if necessary.
8. Remove rotor arm.
9. Rotate distributor to position pick-up opposite nearest reluctor tooth.

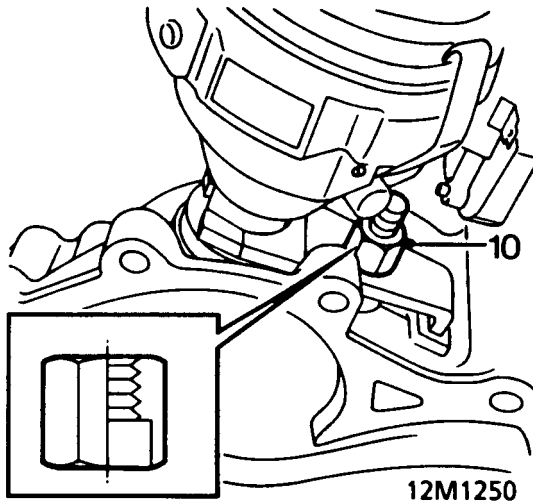

10. Fit distributor clamp nut ensuring that counterbored portion is towards clamp; tighten nut.
11. Fit rotor arm.



**CAUTION:** This distributor setting is to enable engine to be started. When engine is refitted, ignition timing must be set using electronic equipment.

## OIL COOLER ADAPTER - ENGINE NUMBERS WITHOUT SUFFIX B

### Oil cooler adapter - remove

1. Remove oil filter element.

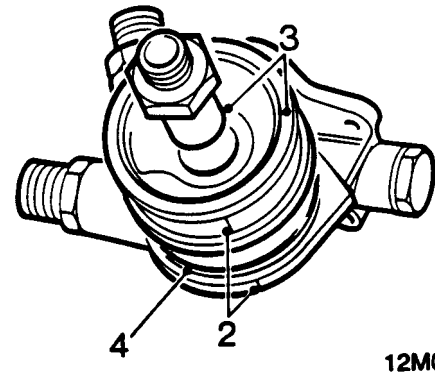

12M0920

2. Mark position of adapter in relation to oil pump cover.
3. Remove centre screw and withdraw adapter.
4. Remove and discard sealing ring.

### Oil cooler adapter - refit

1. Thoroughly clean adapter.
2. Position new sealing ring, fit adapter, ensuring marks previously made line up, fit and tighten centre screw.
3. Lubricate sealing ring of oil filter with engine oil.
4. Screw filter on to filter head until it seats then tighten a further half-turn.

# ENGINE

## OIL PUMP - ENGINE NUMBERS WITHOUT SUFFIX B

### Oil pump - remove

1. Remove sump.
2. Remove distributor.
3. Remove timing cover.
4. Remove oil cooler adapter - if fitted.

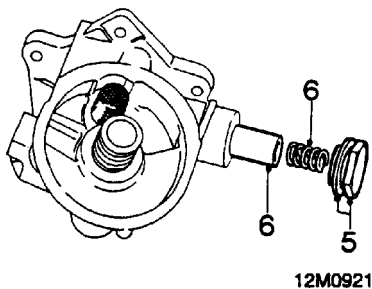

5. Remove oil pressure relief valve plug, discard sealing washer.
6. Withdraw pressure relief valve spring and valve.

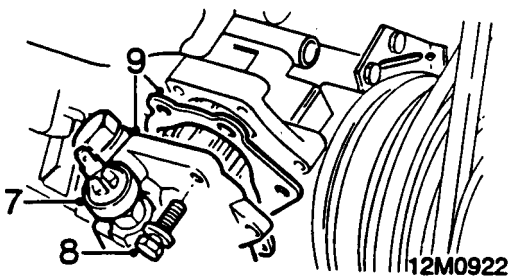

7. Remove oil pressure switch, discard sealing washer.
8. Remove bolts securing oil pump cover.
9. Remove cover, remove and discard gasket.
10. Withdraw oil pump gears.

### Oil pump - inspection

1. Thoroughly clean oil pump gear housing, cover and gears.
2. Clean oil pressure relief valve bore in housing.
3. Clean relief valve filter screen.
4. Inspect pump gears for wear and scoring.

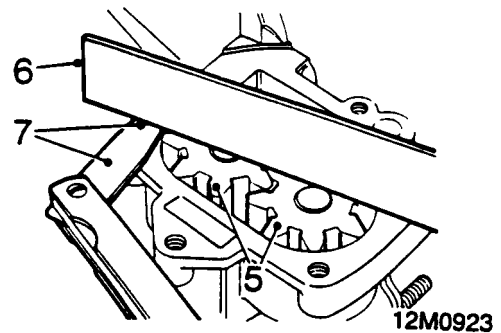

5. Fit pump gears into housing.
6. Place straight edge across gears.
7. Check clearance between straight edge and housing face.  
Gear to housing minimum clearance = 0.05mm.  
If clearance is below minimum specified check gear recess in housing for wear. Renew housing if necessary.
8. Remove oil pump gears from housing.
9. Clean oil pressure relief valve and spring.
10. Inspect relief valve for wear and scoring.
11. Inspect relief valve spring for wear or signs of collapse.  
Relief valve free length = 81.28 mm.
12. Check relief valve slides freely in its bore with no perceptible side movement.





### Oil pump - refit

1. Lubricate relief valve, spring, and bore in housing with clean engine oil.
2. Fit relief valve and valve spring.
3. Fit new sealing washer to plug, fit plug and tighten to correct torque.
4. Pack oil pump housing with Petroleum Jelly.



**CAUTION:** Use only Petroleum Jelly, no other grease is suitable.

5. Fit oil pump gears ensuring that Petroleum Jelly is forced into every cavity between teeth of gears.



**CAUTION:** Unless pump is fully packed with Petroleum Jelly it may not prime itself when the engine is started.

6. Fit new pump cover gasket.
7. Position cover, fit bolts and tighten progressively to correct torque.
8. Fit oil cooler adapter.
9. Fit timing cover.
10. Fit distributor.
11. Fit sump.

### OIL PUMP - ENGINE NUMBERS WITH SUFFIX B



**CAUTION:** Overhaul procedures for the oil pump and oil pressure relief valve are limited to carrying out dimensional checks. In the event of wear or damage being found, a replacement timing cover assembly must be fitted.

### Oil pump - remove

1. Remove timing cover.

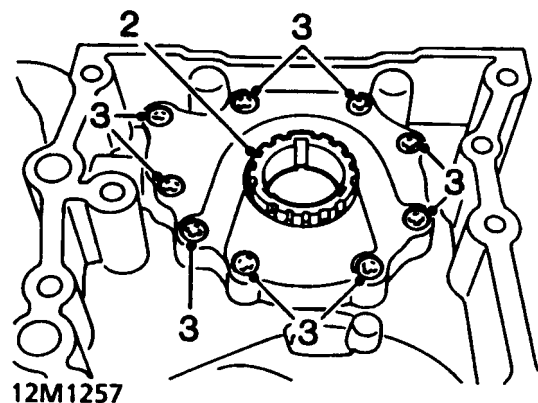

2. Remove oil pump drive gear.
3. Remove 9 screws securing cover plate, remove plate.

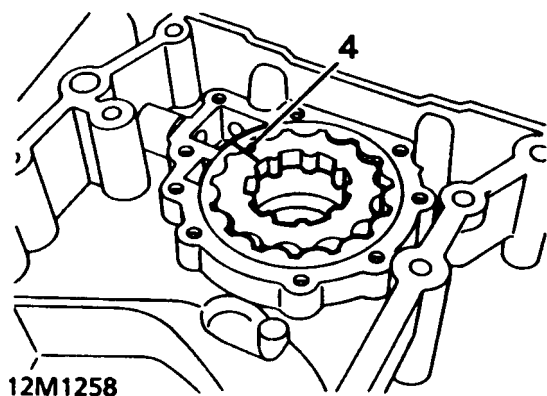

4. Make suitable alignment marks on inner and outer rotors, remove rotors.

# ENGINE

## Oil pressure relief valve - remove

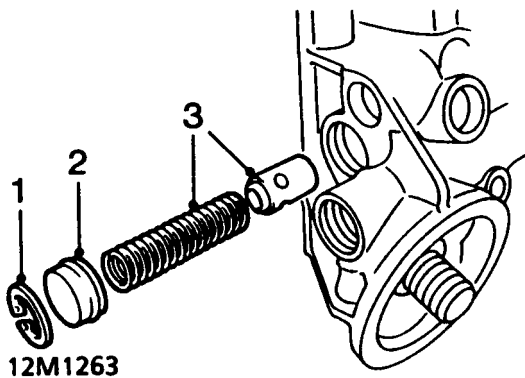

1. Remove circlip.
2. Remove relief valve plug, remove and discard 'O' ring.
3. Remove relief valve spring and piston.

## Oil pump - inspection

1. Thoroughly clean oil pump drive gear, cover plate, rotors and housing. Remove all traces of Loctite from cover plate securing screws; ensure tapped holes in timing cover are clean and free from oil.
2. Check mating surfaces of cover plate, rotors and housing for scoring.
3. Assemble rotors and oil pump drive gear in housing ensuring that reference marks are aligned.

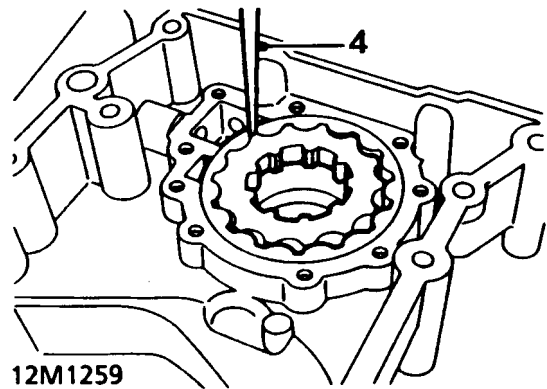

4. Using feeler gauges, check clearance between teeth of inner and outer rotors:  
Maximum clearance = 0.25 mm

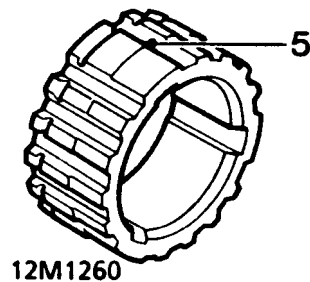

5. Remove oil pump drive gear, check depth of any wear steps on gear teeth:  
Wear step maximum depth = 0.15 mm

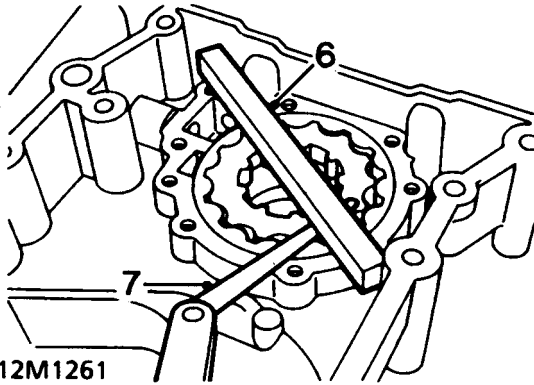

6. Place a straight edge across housing.
7. Using feeler gauges, check clearance between straight edge and rotors:  
Maximum clearance = 0.1 mm

#### Oil pressure relief valve - inspection

1. Clean relief valve components and piston bore in timing cover.
2. Check piston and bore for scoring and that piston slides freely in bore with no perceptible side movement.
3. Check relief valve spring for damage and distortion; check spring free length:  
Spring free length = 60.0 mm

#### Oil pump - refit

1. Lubricate rotors, oil pump drive gear, cover plate and housing with engine oil.
2. Assemble rotors in housing ensuring that reference marks are aligned.
3. Position cover plate to housing.
4. Apply Loctite 222 to threads of cover plate screws, fit but do not fully tighten screws.
5. Position drive gear in oil pump, tighten cover plate screws to correct torque.
6. Fit timing cover.

#### Oil pressure relief valve - refit

1. Lubricate new 'O' ring with engine oil and fit to relief valve plug.
2. Lubricate relief valve spring, piston and piston bore with engine oil.
3. Assemble piston to relief valve spring, insert piston and spring into piston bore.
4. Fit relief valve plug, depress plug and fit circlip.
5. Ensure circlip is fully seated in groove.

# ENGINE

## CAMSHAFT AND TAPPETS

### Camshaft and tappets - remove

1. Remove rocker shaft assemblies.
2. Remove pushrods and store in fitted order.
3. Remove timing chain and gears.

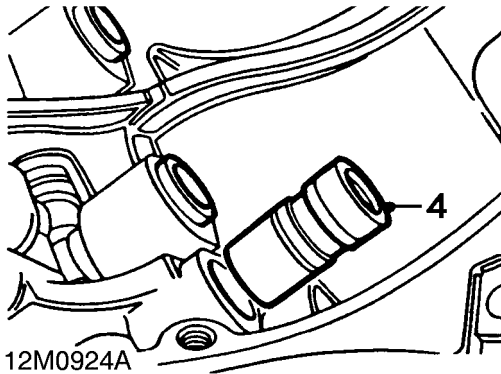

4. Remove tappets and retain with their respective pushrods.

△ **NOTE:** If tappets cannot be removed due to damaged camshaft contact area, proceed as follows:

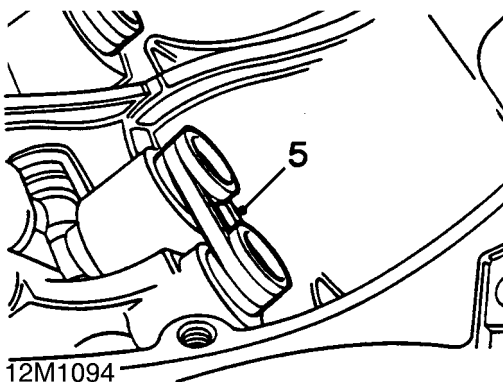

5. Lift tappets in pairs to the point where damaged face is about to enter tappet bore and fit rubber bands to retain tappets. Repeat until all tappets are retained clear of camshaft lobes. The tappets can then be withdrawn out the bottom of their bores when the sump is removed.

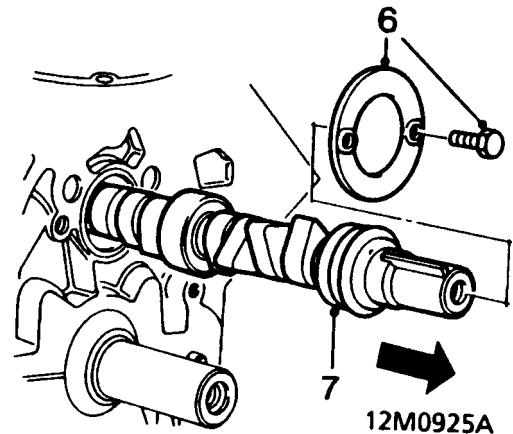

6. Withdraw camshaft, taking care not to damage bearings in cylinder block.

### Camshaft and tappets - inspection

1. Thoroughly clean all components.
2. Inspect camshaft bearing journals and lobes for signs of wear, pitting, scoring and overheating.
3. Support camshaft front and rear bearings on vee blocks, and using a DTI, measure camshaft run-out on centre bearing. Maximum permitted run-out = 0.05 mm.
4. Clean and inspect tappets. Check for an even, circular wear pattern on the camshaft contact area. If contact area is pitted or a square wear pattern has developed, tappet must be renewed.
5. Inspect tappet body for excessive wear or scoring. Replace tappet if scoring or deep wear patterns extend up to oil feed area. Clean and inspect tappet bores in engine block.
6. Ensure that tappets rotate freely in their respective bores.
7. Inspect pushrod contact area of tappet, replace tappet if surface is rough or pitted.



### Camshaft and tappets - refit

1. Lubricate camshaft journals with clean engine oil and carefully insert camshaft into cylinder block.
2. Immerse tappets in clean engine oil. Before fitting, pump the inner sleeve of tappet several times using a pushrod, to prime tappet and reduce tappet noise when engine is first started.
3. Lubricate tappet bores with clean engine oil and fit tappets in removed order.



**NOTE:** Some tappet noise may be evident on initial start-up. If necessary, run the engine at 2500 rev/min for a few minutes until noise ceases.

4. Fit timing chain and gears.
5. Fit rocker shaft assemblies.

### PISTONS, CONNECTING RODS, PISTON RINGS AND CYLINDER BORES

#### Pistons and connecting rods - remove

1. Remove cylinder head(s).
2. Remove big-end bearings.
3. Remove carbon ridge from top of each cylinder bore.
4. Suitably identify each piston to its respective cylinder bore.
5. Push connecting rod and piston assembly to top of cylinder bore and withdraw assembly.
6. Remove plastic tubing from connecting rod bolts.
7. Repeat above procedure for remaining pistons.

#### Piston rings - remove

1. Using a suitable piston ring expander, remove piston rings.
2. Remove carbon from piston ring grooves.



**NOTE:** Use an old broken piston ring with a squared off end.



**CAUTION:** Do not use a wire brush.

#### Piston rings - inspection

1. Temporarily fit new compression rings to piston.



**NOTE:** The ring marked 'TOP' must be fitted, with marking uppermost, into second groove. The chrome ring fits into top groove and can be fitted either way round.

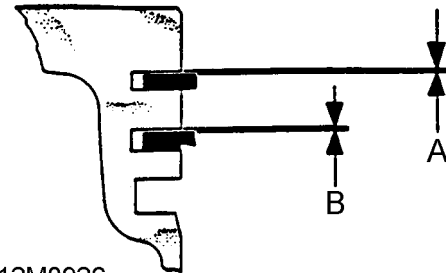

12M0926

2. Check compression ring to groove clearance:  
Top compression ring **A** = 0.05 to 0.10 mm.  
2nd compression ring **B** = 0.05 to 0.10 mm.

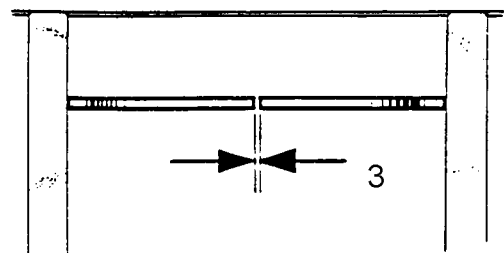

12M0927

3. Insert new piston ring into relevant cylinder, held square to bore with piston, and check ring gaps.  
Top compression ring = 0.44 to 0.57 mm.  
2nd compression ring = 0.44 to 0.57 mm.  
Oil control ring rails = 0.38 to 1.40 mm.
4. Use a fine-cut flat file to increase gap if required. Select a new piston ring if gap exceeds limit.

# ENGINE

## Pistons - remove

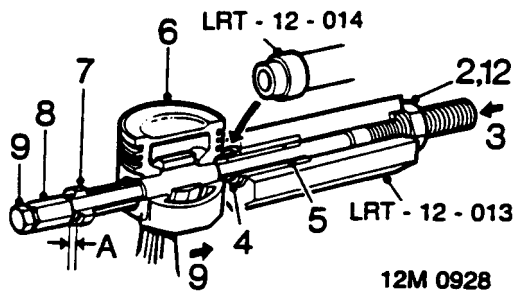

1. Clamp hexagon body of **LRT-12-013** in vice.
2. Screw large nut back until flush with end of centre screw.
3. Push centre screw forward until nut contacts thrust race.
4. Locate piston adapter **LRT-12-014** with its long spigot inside bore of hexagon body.
5. Fit parallel sleeve, grooved end first, onto centre screw and smear outside diameter with engine oil.
6. Locate piston and connecting rod assembly on centre screw and up to adapter **LRT-12-014**.
7. Fit remover/replacer bush of **LRT-12-014** on centre screw with flanged end away from gudgeon pin.
8. Screw stop nut onto centre screw leaving clearance **A**, between nut and remover/replacer bush.  
Clearance **A** = 3 mm.
9. Lock the stop nut securely with lock screw.
10. Push connecting rod to right to locate end of gudgeon pin in adapter **LRT-12-014**.
11. Ensure remover/replacer is located in gudgeon pin bore of piston.
12. Screw large nut up to thrust race.
13. Hold lock screw and turn large nut until gudgeon pin is withdrawn from piston.
14. Dismantle tool and remove piston, connecting rod and gudgeon pin.
15. Repeat above operation for remaining pistons.

## Pistons - inspection

1. Clean carbon from pistons
2. Inspect pistons for distortion and cracks.

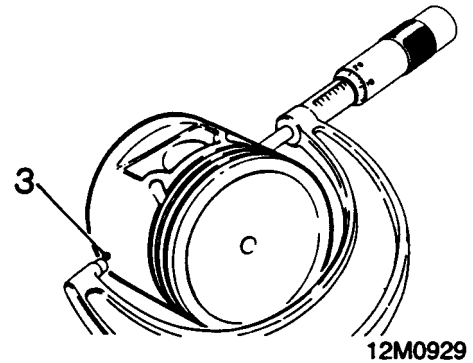

3. Measure piston diameter at 90° to gudgeon pin axis and 8 mm from bottom of skirt. The piston must be 0.018 mm to 0.033 mm smaller than cylinder bore.



### Cylinder bore - inspection

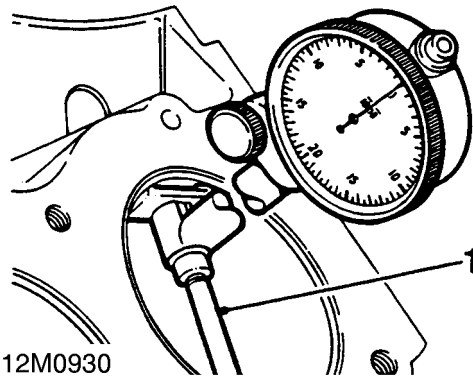

1. Measure cylinder bore wear in two axis 40 to 50 mm from top of bore.  
Piston to cylinder bore clearance = 0.018 to 0.033 mm.

**NOTE:** Pistons are available in service standard size and 0.508 mm oversize. Service standard size pistons are supplied 0.0254 mm oversize. When fitting new service standard size pistons, check for correct piston to bore clearance, hone bore if necessary.

**CAUTION:** The temperature of piston and cylinder block must be the same to ensure accurate measurement. When reboring cylinder block, the crankshaft main bearing caps must be fitted and bolts tighten to correct torque.

2. If only new piston rings are to be fitted, break cylinder bore glazing using a fine grit, to produce a 60° cross-hatch finish.

**CAUTION:** Ensure all traces of grit are removed after above operation.

### Connecting rod - inspection

1. Check alignment of connecting rod.

### Pistons - refit

**CAUTION:** On later 4.2L engines the piston has a 0.5 mm offset gudgeon pin which can be identified by an arrow mark on the piston crown. This arrow **MUST** always point to the front of the engine.

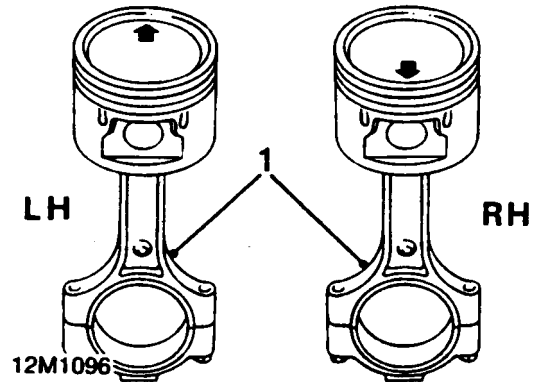

1. *4.2L engine only:* Assemble pistons to connecting rods with arrow on piston pointing towards domed shaped boss on connecting rod for RH bank of cylinders, and arrow pointing away from dome shaped boss for LH bank of cylinders.

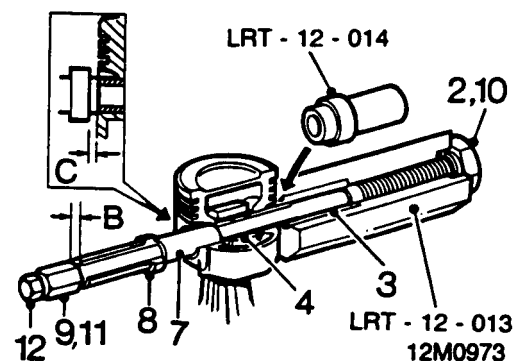

2. Clamp hexagon body of LRT-12-013 in vice.
3. Remove large nut and pull the centre screw 50 mm out of hexagon body.
4. Locate piston adapter LRT-12-014 with its long spigot inside bore of hexagon body.
5. Fit parallel sleeve, grooved end last, up to shoulder on centre screw.
6. Lubricate gudgeon pin and bores of connecting rod and piston with graphited oil.
7. Locate connecting rod and piston to centre screw with connecting rod entered on sleeve up to groove.

## ENGINE

8. Fit gudgeon pin onto centre screw and into piston bore up to connecting rod.
9. Fit remover/replacer bush with flanged end towards gudgeon pin.
10. Screw the stop nut onto centre screw and position piston against face of adaptor **LRT-12-014**.
11. Lubricate centre screw threads and thrust race with graphited oil, fit, and screw large nut up to thrust race.
12. Adjust stop nut leaving clearance **B**, between nut and remover/replacer bush.  
Clearance **B** = 0.8 mm.
13. Lock the stop nut securely with lockscrew.
14. Set torque wrench to 16 Nm, and using socket on large nut, pull gudgeon pin in until flange of remover/replacer bush is distance **C** from face of piston.  
Distance **C** = 4 mm.



**CAUTION: Flange of remover/replacer must not be allowed to contact piston. If torque figure is not achieved during above operation, fit of gudgeon pin to connecting rod is not acceptable and necessitates renewal of components. The centre screw and thrust race must be kept well lubricated throughout operation.**

15. Dismantle tool, remove piston, check no damage has occurred during pressing and piston moves freely on gudgeon pin.
16. Repeat above operation for remaining pistons.

### Pistons and connecting rods - refit

1. Fit oil control ring rails and expander, ensuring ends butt and not overlap.

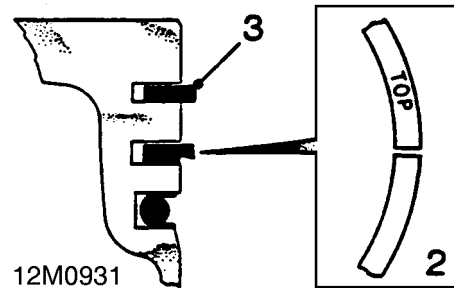

2. Fit ring marked 'TOP' with marking uppermost into second groove.
3. Fit top compression ring into groove either way round.

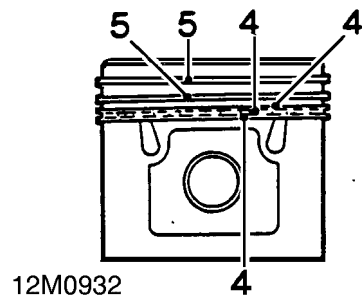

4. Position oil control expander ring joint and ring rail gaps all at one side, between gudgeon pin and piston thrust face. Space gaps in ring rails approximately 25 mm each side of expander ring joint.
5. Position compression rings with ring gaps on opposite sides of piston between gudgeon pin and piston thrust face.
6. Fit big-end bearing shell to connecting rod.
7. Lubricate big-end bearing shell, piston rings and gudgeon pin with engine oil.
8. Lubricate cylinder bores and crankshaft big-end journals with engine oil.



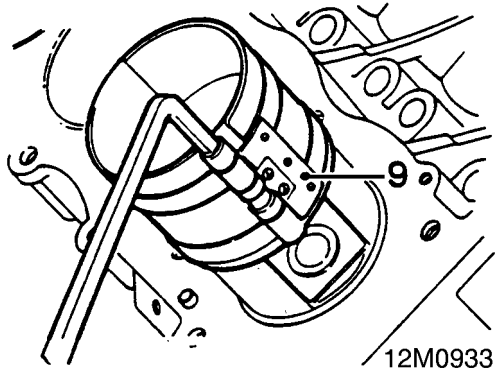

9. Fit ring clamp to piston and compress piston rings.
10. Fit plastic tubing to connecting rod bolts.

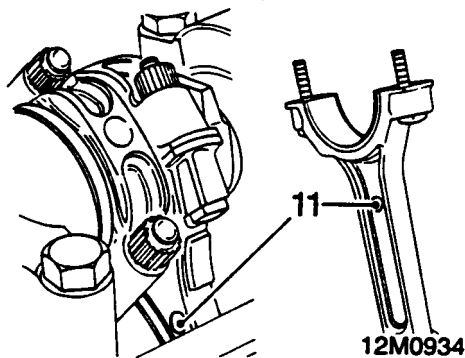

11. Insert connecting rod and piston assembly into respective cylinder bore ensuring domed shaped boss on connecting rod faces towards front of engine on RH bank of cylinders, and towards rear on LH bank of cylinders.



**NOTE:** When both connecting rods are fitted to each journal, bosses will face towards each other.

12. Pull connecting rod on to crankshaft journal.



**CAUTION:** Take care not to scratch crankshaft journals.

13. Fit big-end bearing caps and bearing shells.
14. Fit cylinder head(s).

**FLYWHEEL**

**Flywheel- remove**

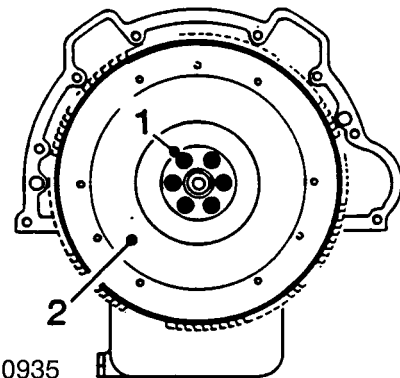

1. Restrain crankshaft and remove 6 bolts securing flywheel.
2. Remove flywheel.

**Inspect**

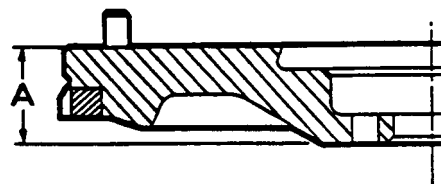

12M0936

1. Inspect flywheel face for cracks, scores and overheating. The flywheel can be refaced providing thickness does not go below minimum.  
Flywheel minimum thickness **A** = 39.93 mm
2. Inspect ring gear for worn, chipped and broken teeth.
3. Renew ring gear if necessary.

## Flywheel ring gear - renew

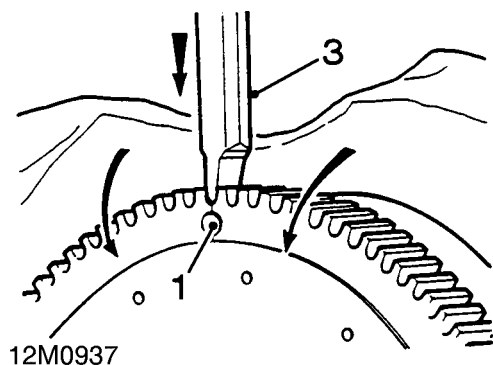

1. Drill a 10 mm diameter hole axially at base of tooth and inner diameter of starter ring, sufficiently deep enough to weaken ring gear.



**CAUTION: Do not allow drill to enter flywheel.**

2. Secure flywheel in soft jawed vice.
3. Split ring gear using a cold chisel.



**WARNING: Wear safety goggles and take precautions against flying fragments when splitting ring gear.**

4. Remove flywheel from vice, remove old ring gear, and place flywheel, clutch side down, on a flat surface.

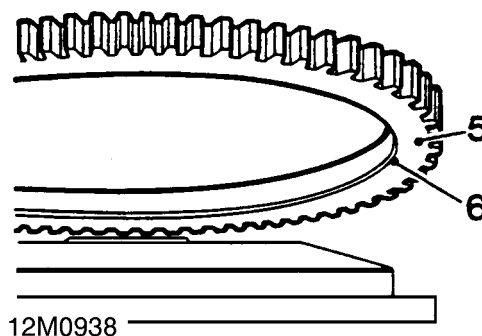

5. Heat new ring gear uniformly to between 170° and 175° C.



**CAUTION: Do not exceed this temperature.**

6. Locate ring gear on flywheel with chamfered inner diameter towards flywheel flange.



**NOTE: If ring gear is chamfered on both sides, it can be fitted either way round.**

7. Press ring gear onto flywheel until it butts against flywheel flange.
8. Allow flywheel to air cool.

## Flywheel - refit

1. Fit flywheel and locate on 2 dowels.
2. Fit flywheel bolts.
3. With assistance, restrain crankshaft and tighten flywheel bolts to correct torque.



## DRIVE PLATE AND RING GEAR ASSEMBLY

### Drive plate and ring gear assembly - remove

1. Mark each component to enable reassembly in original position.

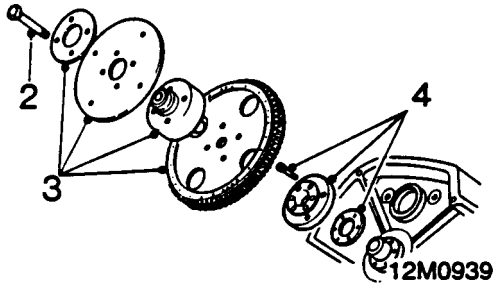

2. Remove 4 bolts securing drive plate.
3. Remove clamp ring, flexible drive plate, hub aligner and ring gear assembly.
4. Remove 6 socket head screws securing crankshaft adapter plate, remove adapter plate and selective shim.

### Inspect

1. Inspect flexible drive plate for cracks and distortion.
2. Renew drive plate if necessary.
3. Inspect ring gear for worn, chipped and broken teeth.
4. Renew ring gear assembly if necessary.

### Drive plate and ring gear assembly - refit



**CAUTION:** To prevent distortion to flexible drive plate when bolted to torque converter, drive plate setting height must be checked as follows:

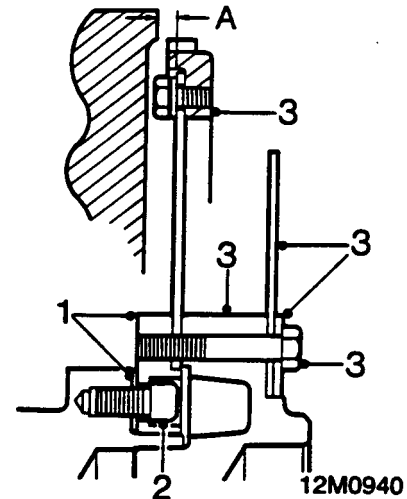

1. Fit existing shim and crankshaft adapter plate.
2. Fit socket head screws and lightly tighten.
3. Fit ring gear assembly, hub aligner, drive plate and clamping ring, fit bolts and lightly tighten.
4. Check the setting height.  
Drive plate setting height  $A = 8.08$  to  $8.20$  mm.
5. Remove bolts, remove clamp ring, flexible drive plate, hub aligner and ring gear assembly.
6. Remove socket head screws, remove crankshaft adapter and shim.

# ENGINE

7. Measure existing shim and, if necessary, select appropriate shim to maintain setting height.

Shims available:

- 1.20 - 1.25mm
- 1.30 - 1.35mm
- 1.40 - 1.45mm
- 1.50 - 1.55mm
- 1.60 - 1.65mm
- 1.70 - 1.75mm
- 1.80 - 1.85mm
- 1.90 - 1.95mm
- 2.00 - 2.05mm
- 2.10 - 2.15mm

8. Fit shim selected, position adapter, ensuring marks previously made line up, fit socket head bolts and tighten to correct torque.
9. Fit ring gear assembly, hub aligner, flexible drive plate and clamp ring, ensuring marks previously made line up.
10. Apply Loctite 242 to threads of bolts, fit bolts and tighten to correct torque.

## CRANKSHAFT, MAIN AND BIG-END BEARINGS

### Crankshaft end - float - check

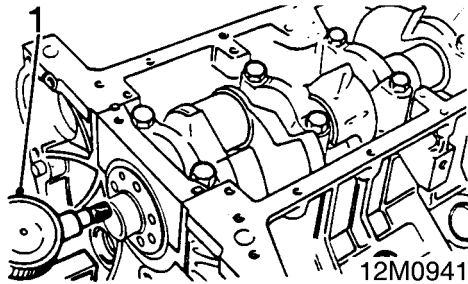

1. Set-up DTI to measure end float.
2. Move crankshaft forwards and zero gauge.
3. Move crankshaft rearwards, record end-float reading obtained.  
Crankshaft end-float = 0.10 to 0.20mm.
4. Remove DTI.



**NOTE:** Crankshaft end-float is controlled by thrust faces on upper half of centre main bearing shell.

### Big-end bearings - remove

1. Remove sump.

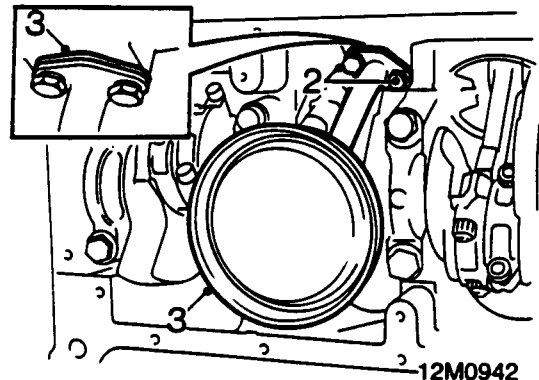

2. Remove 2 bolts securing oil strainer.
3. Remove strainer, remove and discard gasket.
4. Suitably identify bearing caps to their respective connecting rods.

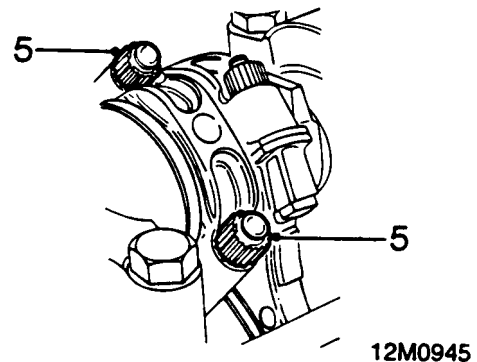

5. Remove 2 nuts securing each bearing cap.
6. Remove bearing cap and bearing shell.



**CAUTION:** Keep bearing caps and shells in their fitted order.

7. Fit a length of plastic tubing over each connecting rod bolt.
8. Push each piston up its respective bore and remove shells from connecting rods.



**CAUTION:** Keep bearing shells in their fitted order.



### Big-end bearings - Inspection

1. Check big-end bearing shells for wear and damage.
2. Renew big-end bearing shells as necessary.



**NOTE: Big-end bearings are available in 0.254 mm and 0.508 mm undersizes.**

### Big-end bearings - refit

1. Fit bearing shells to each connecting rod.
2. Lubricate bearing shells and crankshaft journals with clean engine oil.
3. Pull connecting rods onto crankshaft journals and remove plastic tubing.
4. Fit bearing shells to each big-end bearing cap.

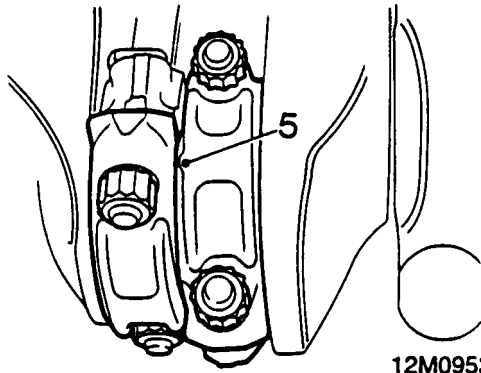

5. Lubricate bearing shells and fit bearing caps ensuring reference marks on connecting rods and bearing caps are aligned.



**NOTE: Rib on edge of bearing cap must face towards front of engine on RH bank of cylinders and towards rear on LH bank of cylinders.**

6. Fit bearing cap nuts and tighten to correct torque.
7. Check connecting rods move freely sideways on crankshaft. Tightness indicates insufficient bearing clearance or misaligned connecting rod.

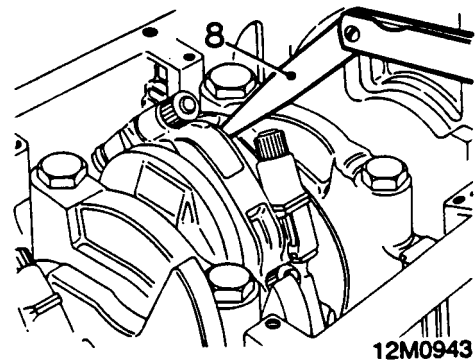

8. Check clearance between connecting rods on each crankshaft journal.  
Connecting rod clearance = 0.15 to 0.37 mm.
9. Clean oil strainer.
10. Clean gasket mating faces on strainer and cylinder block.
11. Fit gasket to strainer, position strainer, fit bolts and tighten to correct torque.
12. Fit sump.

# ENGINE

## Crankshaft - remove

1. Remove flywheel or drive plate and ring gear assembly.
2. Remove timing cover.
3. Remove timing gears.
4. Remove big-end bearings.

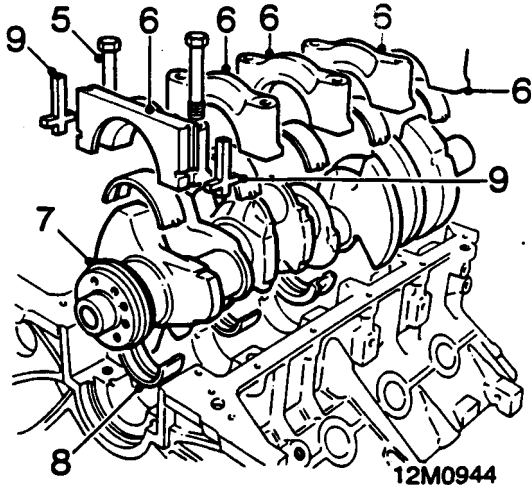

5. Starting at centre main bearing and working outwards, progressively slacken then remove 10 main bearing cap bolts.
6. Remove 5 main bearing caps and bearing shells, retain bearings with their caps.
7. Lift out crankshaft and rear oil seal. Remove and discard oil seal.
8. Remove 5 bearing shells from cylinder block and retain in their fitted order.
9. Remove and discard side seals from rear main bearing cap.
10. Remove Woodruff key from crankshaft.

## Crankshaft - inspection

1. Clean crankshaft and blow out oil passages.

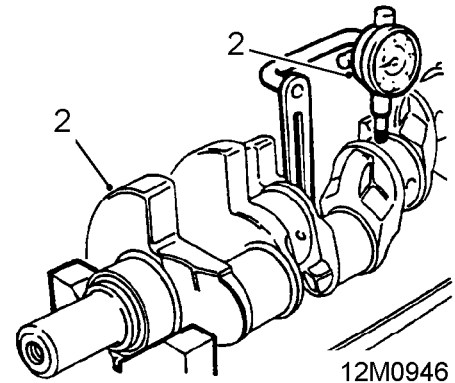

2. Support crankshaft front and rear bearings on vee blocks, and using a DTI, measure run-out on centre main bearing.  
Maximum permitted run-out = 0.08 mm.  
If run-out exceeds permitted maximum, crankshaft is unsuitable for regrinding and should be renewed.
3. Measure each journal for overall wear and ovality.  
Main bearing journal diameter = 58.409 to 58.422 mm  
Maximum out of round = 0.040 mm.  
Big-end bearing journal diameter = 50.800 to 50.812 mm  
Maximum out of round = 0.040 mm.  
If measurements exceed permitted maximum, regrind or fit new crankshaft.



**NOTE:** Ovality checks should be made at 120° intervals around each journal.  
Crankshaft main bearings are available in 0.254 mm and 0.508 mm undersizes. When fitting 0.508 mm undersize bearings, centre main bearing, which controls crankshaft end-float, has thrust faces increased in thickness by 0.254 mm. Therefore if 0.508 mm undersize bearings are fitted, 0.127 mm must be machined off each thrust face of centre main bearing journal to maintain correct radius.



### Crankshaft dimensions:

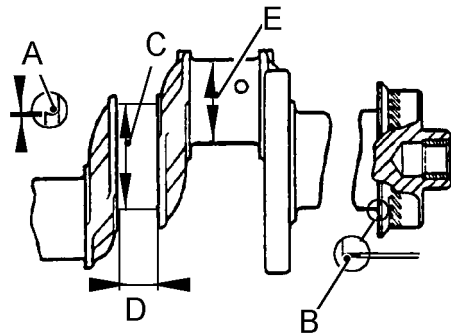

12M0947

Bearing journal radius - all journals except rear main journal **A** = 1.90 to 2.28 mm.

Rear main bearing journal radius **B** = 3.04 mm.

Bearing journal diameter **C** :

Standard = 58.400 to 58.413 mm.

0.254 mm undersize = 58.146 to 58.158 mm.

0.508 mm undersize = 57.892 to 57.904 mm.

Bearing journal width **D** :

Standard = 26.975 to 27.026 mm.

0.254 mm undersize = 26.975 to 27.026 mm.

0.508 mm undersize = 27.229 to 27.280 mm.

Bearing journal diameter **E** :

Standard = 50.800 to 50.812 mm.

0.254 mm undersize = 50.546 to 50.559 mm.

0.508 mm undersize = 50.292 to 50.305 mm.

### Crankshaft spigot bearing - renew

1. Carefully extract old spigot bearing.
2. Clean bearing recess in crankshaft.

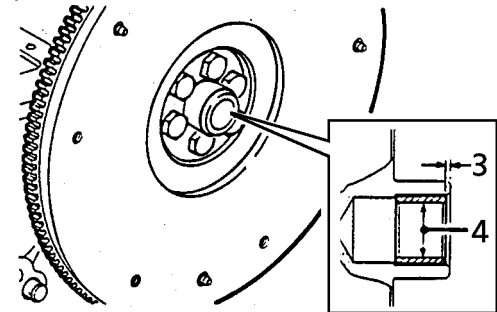

12M0948

3. Fit new bearing flush with, or to a maximum of 1.6 mm below end face of crankshaft.
4. Ream bearing to correct inside diameter.  
Spigot bearing inside diameter = 19.177 + 0.025 mm.
5. Remove all traces of swarfe.

### Crankshaft - refit

1. Clean main bearing caps, bearing shell recesses and mating surfaces of cylinder block.

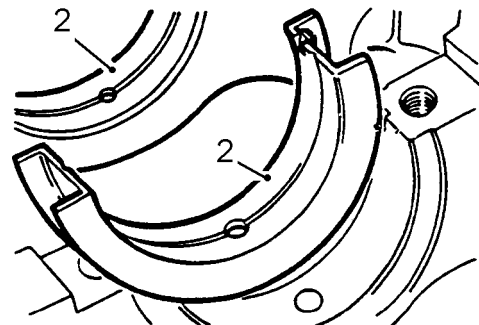

12M0949

2. Fit upper main bearing shells, with oil holes and grooves, in cylinder block, ensuring flanged shell is fitted in centre position.
3. Lubricate bearing shells with clean engine oil and position crankshaft in cylinder block.
4. Fit main bearing shells to bearing caps.

5. Apply EXP16A (Marston Lubricants) lubricant to threads of main bearing cap bolts.
6. Lubricate main bearing shells and fit numbers 1 to 4 bearing caps, fit and lightly tighten bolts.

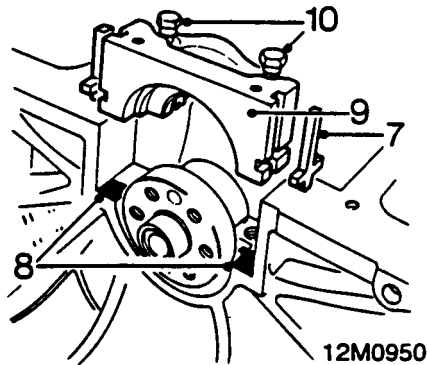

7. Fit side seals to rear main bearing cap.



**CAUTION: Seals must protrude approximately 1.5 mm above bearing cap face.**

8. Apply Hylomar SQ32M jointing compound to bearing cap rear mating face on cylinder block.
9. Lubricate bearing shell and side seals with clean engine oil, carefully fit bearing cap assembly.
10. Fit bolts and lightly tighten.
11. Clean seal location and running surface on crankshaft.
12. *Engine numbers without suffix B:* Clean seal protector **LRT-12-010** and lubricate with engine oil.
13. *Engine numbers with suffix B:* Clean seal protector **LRT-12-095** and lubricate with engine oil.
14. Lubricate oil seal lip with engine oil.

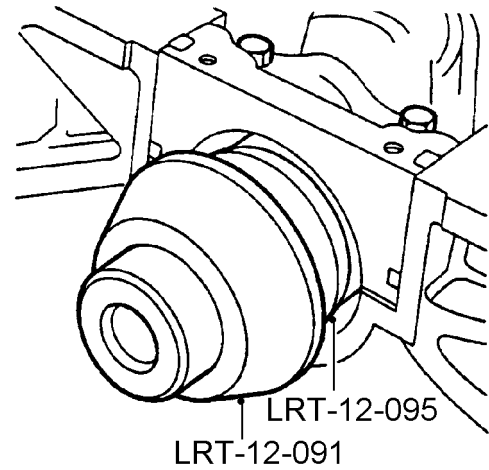

12M1255A



**NOTE: Seal protector LRT-12-095 illustrated.**

15. Position seal protector to crankshaft.
16. *Engine numbers without suffix B:* Fit oil seal squarely using hand pressure only until fully seated in recess.
17. *Engine numbers with suffix B:* Fit seal using tool **LRT-12-091**.
18. Tighten main bearing cap bolts to correct torque.
19. Fit Woodruff key to crankshaft.
20. Check crankshaft end-float.
21. Fit big-end bearings.
22. Fit timing cover and gears.
23. Fit flywheel or drive plate and ring gear assembly.





---

**SERVICE TOOLS**

---

Land Rover Number	Rover Number	Description
LRT-12-010*	18G 1014*	Protection sleeve - crankshaft rear oil seal
LRT-12-013	18G 1150	Remover/replacer gudgeon pin
LRT-12-014	18G 1150E	Adaptor remover/replacer gudgeon pin
LRT-12-034	18G 1519	Valve spring compressor
LRT-12-037	RO.274401	Drift remover - valve guide
LRT-12-038	RO.600959	Drift replacer - valve guide
LRT-12-055		Distance piece - valve guide
LRT-12-089**		Replacer - timing cover oil seal
LRT-12-090**		Retainer - oil pump gears
LRT-12-091**		Replace - crankshaft rear oil seal
LRT-12-095**		Protection sleeve - crankshaft rear oil seal
LRT-12-501	MS76B	Basic handle set - valve seat cutters
LRT-12-503	MS150-8.5	Adjustable valve seat pilot
LRT-12-504	MS76-621	Adjustable valve seat cutter
LRT-12-515	RO.605774A	Distance piece - valve guide

\* Engine numbers without suffix B \*\* Engine numbers with suffix B

Service tools must be obtained direct from the manufacturers:

V.L. Churchill,  
P.O. Box No 3,  
London Road,  
Daventry,  
Northants, NN11 4NF.  
England.